



ADELAIDE RALLY
• 2024 •

**2024 SHANNONS
ADELAIDE RALLY**
NOVEMBER 8-10



ROAD BOOK

ADELAIDE RALLY

• 2024 •

Event Map

8 - 10 November



12 Hermitage

13 Chain of Ponds Long

17 Millbrook

4 & 7 Cherryville Plus

14 Corkscrew Plus

8 Stafford Hillclimb

15 & 19 Norton Summit

3 & 9 Knotts Hill

6 & 10 Old Norton Summit

23 Mt. Lofty

16 Forest Range

1 Beaumont

2 - Eagle on the Hill
21 Leewood Gardens

11 Summit Road

22 Windy Point

20 Wairoa

30 Sturt Valley

24 Mylor
29 Warrawong

26 & 28 Macclesfield

25 & 27 Strathalbyn Town



Road Book Instructions

Crews are advised that the road book was created and checked using only GPS Tripmeters.

GPS accuracy can vary slightly from day to day, and crews will experience some minor variations in distances – especially noticeable on the longer road sections. It is recommended you also use the part distances to reset at each instruction to reduce any variances.

The road book instructions are intended to guide you in a navigation sense and DO NOT attempt to help you choose the speed at which to travel.

The Instructions cannot, and must not, be used as any form of 'pace notes'.

Crews who do not undertake a pre-event reconnaissance are especially warned they choose their speed based on their visual reading of the road ahead.

Warnings of upcoming bends are only included in a few instances where it was felt the visual approach was particularly deceptive.

The roads used in this event are very demanding and contain numerous very tight and narrow bends – some with steep drops, rocks, or Armco railing.

Accordingly, we advise crews that they are totally responsible for the manner and speed in which they traverse the course, and ultimately their own safety.

Crews should be taking their own experience and abilities into account, and so traverse the course in the manner and speed at which they are comfortable.

Emergency Phone Number:

8410 8100



Road Book Rules

1. This road book was compiled:
 - a. At below legal speed limits
 - b. Whilst driving on the left hand side of the road
 - c. In dry weather conditions
2. Follow the main road that you are on unless otherwise instructed.
3. Every bend and hump in the road is not included in these instructions.
4. Instructions are given where it is considered that the characteristics of the road changes, or there is a perceived danger to crews.
5. 60m = 60 metres
6. GPS co-ordinates are given in 'degree, minute-decimal' format, as per GPS Datum WGS 84 (GDA 94).
S 35° 07.854
E 138° 29.662
7. Cautions
 - ! Care** – some care needs to be exercised
 - !! Caution** – a reduction in speed is required
 - !!! Danger** – a severe reduction of speed is required



Speeding Penalties

Crews are reminded that under the **National Rally Standing Regulations – Special Stage Rally**, and **National Rally Standing Regulations – Events General**, penalties will apply for speeding during the Event.

These can be found in the Event’s Supplementary Regulations.

Detection of speed limits may be through notification from the Police, Event Radar or RallySafe Reports.

The number of offences means the number detected during the event, irrespective of speed.

Odometer Check

The official odometer check in the City is done by travelling east along Greenhill Rd between two marked power poles and is **5.64km** long.

The start pole is situated 100m west of Goodwood Rd. It has a sign stating “ODO Start” in white letters on a red background.

The end pole is situated east of Burke St (directly opposite Laurel Ave). It is marked “ODO Finish” in white letters on a red background.





Emergency Procedures

In the event of an accident within a stage, the first line of help is the following competitor.

It is also important that the following competitors are warned of any impending hazard as a result of the accident or incident, such as people or animals on the road, vehicles or debris blocking the course, or fluid spills on the road.

Procedure to be Followed by Crews Involved in an Accident

In the event of an accident of a special stage, the first priority is to warn the following crews of any hazard. If able, the driver and co-driver should leave the vehicle, with the warning triangles from the vehicle and proceed back up the road to place these in a conspicuous position at least 50m and 100m before the car to warn following cars. Should the vehicle be completely off the road, warning triangles should not be placed on the road.

In the event of an accident where no injuries are sustained that require immediate medical attention, the 'OK' sign must be clearly displayed to following cars to allow them to proceed quickly through the stage and without slowing unnecessarily. Both the warning triangles and 'OK' sign must be left on display for the whole length of the period that the car is stopped on the course, regardless of whether the crew remain with the car.

It is important that the 'OK' sign is shown to all other competitors, even if the car has stopped for mechanical reasons.

In the event of any crew member being injured and requiring medical attention, other than from minor cuts and bruises, competitors should display the 'SOS' sign.



Following vehicles must stop to render assistance to any incident.

The immediately following vehicle is to stop and render assistance where they can. The second and third following vehicles to arrive must be sent to the next SOS point or the end of the stage to call for medical assistance.

As this will result in the stage being stopped, competitors are asked to use their judgement on whether medical attention is required immediately, or whether a delay until after the last car will be satisfactory. Competitors are able to talk with medical personnel at Rally Control via mobile telephone on the Event's dedicated emergency number.

In the event of the crew being injured or trapped in the vehicle and no 'OK' or 'SOS' sign being displayed, all following cars must stop at the accident to render assistance.

Procedure to be Followed by Following Vehicles

In the event of a following vehicle sighting the crew members or warning triangles on the road, crews should slow and be ready to stop as there may be an obstruction on the road.

If a member of the crew is displaying the 'OK' sign, crews may continue on the stage at speed, but must be overtly cautious to any obstructions or debris, and advise the control officials at the Stop Point the location of the damaged vehicle and the fact that it is displaying an 'OK' sign. The location is always described as the distance into the stage from the Stage Start.

If a member of the crew is displaying the 'SOS' sign, following vehicles must stop and render assistance. The procedure is that the first vehicle stops at the accident; the second and third vehicles are to proceed immediately to the end of the stage to advise Control officials that medical attention is required.

The first crew should then assist in placing warning triangles to ensure the following competitors are alerted to the accident scene and following crews should carry on to complete the stage in the normal manner. Competitors should position themselves in a safe position to wave following cars through.



In the event that further crews are necessary to assist at the scene of the accident, then the following crews should also be waved down to stop.

Once there are sufficient competitors providing assistance, the 'OK' sign should be displayed to further crews.

In the event of no 'OK' or 'SOS' sign being displayed at the scene of an incident or accident, following crews must stop and investigate and then carry on with the above procedure.

In most locations on the course, mobile telephones will operate effectively. Competitors may carry and use mobile telephones; however they should be turned off while traversing any stage to avoid distraction.

Competitors should try the mobile telephone en-route to the next SOS point or stage finish. Contact the Rally Control Emergency telephone number on **(08) 8410 1100**.

Competitors who stop to render assistance at an accident may be given a derived time in accordance with the supplementary regulations.

Recognised Hand Signals

In any case where incident or timing doesn't allow for the display of 'OK' or 'SOS' signs, the following gestures should be used:





ROAD BOOK SYMBOLS









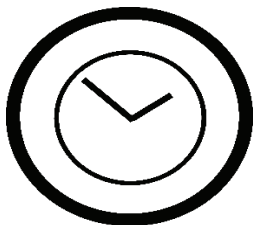
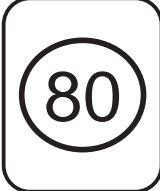
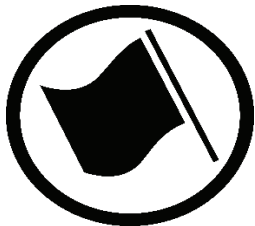

SS	Special Stage	RS	Road Section
BL	Bear Left	RBL	Road Bends Left
BR	Bear Right	RBR	Road Bends Right
SP	Sign Post	RD	Road
FMR	Follow Main Road	RGL	Road Goes Left
FMT	Follow Main Track	RGR	Road Goes Right
KL	Keep Left	RJ	Road Junction
KR	Keep Right	SO	Straight On
TL	Turn Left	TR	Turn Right
THL	Turn Hard Left	TVHL	Turn Very Hard Left
THR	Turn Hard Right	TVHR	Turn Very Hard Right
TJ	Tee' Junction	XR	Cross Road
N	North	E	East
S	South	W	West
!	Care		
!!	Caution		
!!!	Danger		

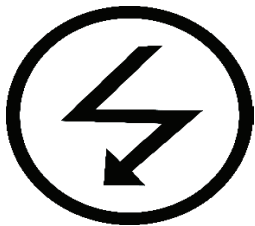

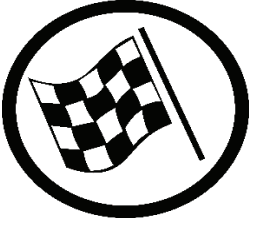
ADELAIDE RALLY

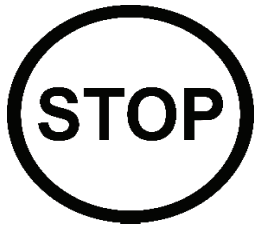
• 2024 •

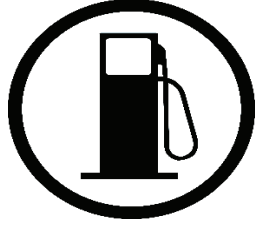
ROAD BOOK SYMBOLS (cont.)

	Time Control		Speed Sign (Indicated Limit)
	Special Stage Start		Sign Post (Indicates Location)
	SOS Point		Give Way Sign
	Flying Finish		Stop Sign
	Stop Point	 	Indicated Signed Road or Marker Signed Marker Do Not Take
	Fuel		Traffic Lights



ROAD MARKINGS

These markings are marked on the road in yellow paint, and correspond to the controls and locations on the previous page.

	Time Control		(Speed) Restriction Start
	Stage Start		(Speed) Restriction End
	Flying Finish		Chicane, Slalom, Slow Point
	Stop Point		! Care
	SOS Point NOTE: Marked in blue paint.		!! Caution
			!!! Danger

ADELAIDE RALLY • 2024 •











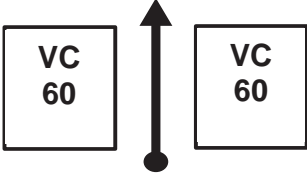
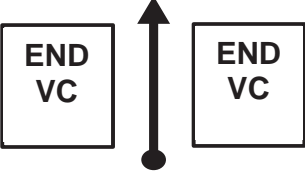

ROAD BOOK SYMBOLS (cont.)

	Culvert		Ruts or Gutter
	Crest		Floodway or Creek
	Dip		Fence or Gate
	Bump, Hump, or Jump		Grid
	Bridge or Causeway		Bank or Rise
	Drop, Washout, or Cutting		Building, Pole, or Structure
	Tree or Trees		Hole or Cavity
	Pipeline		Railing or Barrier
	Side Road or Unused Road		Tyres or Rocks
	Bunting or Tape		Clearing or Quarry
	Rail-Road Crossing		



ADELAIDE RALLY • 2024 •

ROAD BOOK SYMBOLS (cont.)







 	<p style="text-align: center;">Bitumen to Gravel</p> <p style="text-align: center;">Gravel to Bitumen</p>		<p style="text-align: center;">Start Virtual Chicane</p>
	<p style="text-align: center;">End Virtual Chicane</p>		<p style="text-align: center;">Chicane</p>
	<p style="text-align: center;">Slalom, 1/2 Slalom, or Slow Point</p>		<p style="text-align: center;">Barrel Loop</p>
	<p style="text-align: center;">Toilets Available</p>	 	<p style="text-align: center;">Zero Trip Meter Here</p> <p style="text-align: center;">Turn on Camera</p>
 	<p style="text-align: center;">Start Quiet Zone</p> <p style="text-align: center;">End Quiet Zone</p>	 	<p style="text-align: center;">Grey Spot</p> <p style="text-align: center;">Black Spot</p>
<p style="text-align: center;">mm:ss</p> <p style="text-align: center;">hh:mm:ss</p>	<p style="text-align: center;">minutes:seconds</p> <p style="text-align: center;">hours:minutes:seconds</p>	<p style="text-align: center;">S 35° 11.823 E 138° 37.721</p>	<p style="text-align: center;">GPS Location</p>



Competition Roadbook Legend

1	2	3	4	5	6	7	8	9	10	11	12	13	14
Day 1	Your Start Time	Time Allowed	Due Time @ TC		Total Distance	5.85 km							
Section 1	:	0:08:00	:		SS Distance	1.13 km							
TC 1	Hayward Drive				Time Allowed	0:08:00 mins							
TC 2	Mount Barker Road				Average Speed	43.88 km/h							
					SS 1 - Beaumont								

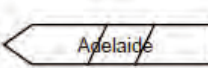
1	Day & Section This indicates the 'Day' or 'Leg' of the event, and the relevant 'Section'. A 'Section' is the collection of 'Special Stages' or 'Liaisons' between Regroups or Parc Ferme.	8	Average Speed This indicates the average speed required to traverse the whole 'Section' in the 'Time Allowed'.
2	Your Start Time Use this space to note the time you are starting the stage. I.e, 10:27:00 (hh:mm:ss).	9	Control Name (Departing) This is usually the name of the road leading into the Time Control (at a Stage Start).
3	Time Allowed This indicates how long it is expected to traverse the Special Stage and subsequent liaison.	10	Control Name (Arriving) This is usually the name of the road leading into the Time Control at the following 'Special Stage' or location.
4	Due Time This is 'Your Start Time' plus 'Time Allowed'. In the case above, 10:35:00.	11	Special Stage Name This is the name of the 'Special Stage'. This may be followed by a numeral which indicates the running of that Stage. I.e, 'Beaumont 2' would indicate the 2 nd running of the 'Beaumont' stage.
5	Total Distance This is the total distance of the 'Section'. I.e, the length of the 'Special Stage', plus the following 'Liaison'.	12	Special Stage Number This is the sequential number of the 'Special Stage'.
6	SS Distance This is the length of the 'Special Stage'.	13	Time Control (Arriving) This 'Time Control' at the <i>end</i> of the 'Section'. Its number is matched to a 'Section' on the Event's Itinerary.
7	Time Allowed This reflects the 'Time Allowed' at '3'.	14	Time Control (Departing) This 'Time Control' at the <i>start</i> of the 'Section'. Its number is matched to a 'Section' on the Event's Itinerary.

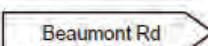
	Distance		Direction	Information	Distance To Go
	Total	Part			
A	1.37	0.42		RGR then RGL	16.96
B			5		
C			0.08		
P	1.45	0.08		Flying Finish S 34° 57.575 E 138° 42.884	16.88
O	1.67	0.22		Stop Point S 34° 57.476 E 138° 42.958	16.66
N	1.72	0.05		TJTR 	16.61
M	FMR through Summertown, Uraidla, and Carey Gully.				
L	11.37	9.65		RJTR 	6.96
			9		

F**G****H****I****J****K**

A	Total Distance This is the distance travelled from the start of the current 'Section'.	I	Absence of Separator Line This indicates that the next instruction is within 200m of the current Tulip. Instructions within 100m of each other are generally included within the same Tulip.
B	Part Distance This is the distance travelled from the previous instruction.	J	Signpost This indicates the location of a signpost relevant to the road travelled.
C	Direction This is called a 'Tulip'. It indicates the shape of the road, and features of the instruction.	K	Signpost Instruction The label indicated by the signpost at 'J'.
D	Information This is a written instruction representing the Tulip's information.	L	Tulip Entry & Exit Instructions are always written relative to the direction being travelled. The 'ball' indicates the starting position of the instruction relative to the road. The arrow indicates the direction of travel once the instruction has been traversed.
E	Distance To Go This is the distance from the next 'Time Control'.	M	Nominal Instruction This is background information supplied in aid of Tulips. It often does not specify a distance.
F	Distance To Go This number indicates the distance to be travelled between the current instruction and the 'Flying Finish'.	N	Un-Shaded Instruction An un-shaded instruction indicated that 'Liaison' or 'Transport Section' is being traversed.
G	GPS Co-Ordinates The precise GPS location of the instruction or Tulip.	O	Shaded Instruction Shading indicates that the course being traversed is Competitive (within a 'Special Stage').
H	Separator Line Used to separate instructions which are more than 200m apart.	P	Instruction Number A 'Tulip Number' indicates the numerical order of instructions within a 'Section'.

Recommended Reconnaissance Order

The reconnaissance order below has been developed to allow strategic and streamlined reconnaissance of all stages within an efficient timeline over two (2) days.

Crews are reminded that unlimited reconnaissance is permitted, with limitations outlined in the event's *Supplementary Regulations*.

Day One Recce Order

From Adelaide, make your way to Fullarton Road, and follow this to Mitcham. Turn right at the roundabout onto Blythewood Road. Turn left at the T-Junction onto Belair Road. Continue to the Windy Point stage.

SS22 - Windy Point

Continue through Belair and turn left on Laffers Road. Turn right at the T-Junction onto Upper Sturt Road. At the next major intersection, give way, and turn left towards Crafers. Turn right onto Sturt Valley Road and continue to the start of Sturt Valley.

SS30 - Sturt Valley

Continue to the T-Junction and turn right onto Longwood Road. Turn left onto Forbes Road and continue to the start of Mylor.

SS24 - Mylor

At the end of this stage, turn around, start the Warrawong stage (start is parallel to the Mylor Flying Finish).

SS29 - Warrawong

Continue to the Cross Road, and turn right onto Emery Road. Follow this onto Edgeware Road. Turn right onto Kingsland Road. At the roundabout in Aldgate, turn left onto Mount Barker Road, and continue to the stage start of Wairoa.

SS20 - Wairoa

Continue through Stirling to the last roundabout, and join the freeway down-track to follow the South Eastern Freeway into Adelaide. Take the Eagle on the Hill exit on the left, and continue to the stage start of Leawood Gardens.

SS21 – Leawood Gardens

Continue following the road left to merge onto the South Eastern Freeway. At the bottom of the Freeway, turn right onto Portrush Road. Turn right onto Giles Road. Turn left onto Sunnyside Road. Turn right onto Sherwood Terrace. Continue to the T-Junction, and turn right onto Hayward Drive. The stage start of Beaumont is on your left shortly.

SS1 - Beaumont

Continue on Mount Osmond Road. Turn left after the Golf Course (this is still Mount Osmond Road). Continue onto the Freeway up-track, and merge onto the Freeway. Take the 'Eagle on the Hill' exit and continue to the stage start of Eagle on the Hill.

SS2 - Eagle on the Hill

At the Stop Point, turn around. This is Leawood Gardens again. Take this opportunity to check your notes.

SS21 - Leawood Gardens

Continue onto the Freeway down-track towards Adelaide. At the bottom of the South Eastern Freeway, turn right onto Portrush Road. Continue on this road, then turn right onto Greenhill Road. Continue to the stage start of Mt. Lofty.

SS23 - Mt. Lofty

NOTE: Once you turn right onto Mount Lofty Summit Road, this road is common to both the Mt. Lofty Stage and the Summit Road stage. The stage start for Summit Road is on your left just after the Greenhill Road intersection.

SS11 - Summit Road

At the stop point, ***turn around***, and turn right onto Greenhill Road at the T-Junction. Continue through Summertown and into Uraidla. Turn left onto Basket Range Road. At the next T-Junction, turn right onto Lobethal Road. Turn left onto Hunters Road and continue to the stage start of Knotts Hill.

SS3 & SS9 - Knotts Hill

At the T-Junction, turn right onto Marble Hill Road. Continue to the stage start of Cherryville Plus.

SS4 & SS7 - Cherryville Plus

Continue on Gorge Road and turn right onto Cuddlee Creek Road. Turn right onto Fox Creek Road and continue to the stage start of Stafford Hillclimb.

SS8 - Stafford Hillclimb

Continue from the stop point, through Lenswood into Adelaide.

Day Two Recce Order

From Adelaide, take Gorge Road through Castambul, continue past Torrens Hill Road, and turn left onto Tippet Road.

SS17 - Millbrook

Continue through Inglewood towards Houghton. Turn left onto Lower North East Road, and continue to the stage start of Vista.

SS5 & SS18 – Vista 1 & 2

After the Stop Point, turn right onto Perseverance Road. At the T-Junction, turn right onto North East Road. Turn left onto Range Road North, and continue to the stage start of Hermitage.

SS12 - Hermitage

From the Stop Point, turn right onto Hannaford Hump Road. Turn right onto Lower Hermitage Road and continue to the T-Junction. Turn left onto Range Road North, then turn left onto North East Road. Continue to the stage start of Chain of Ponds at the Fiddlers Hill Road intersection.

SS13 - Chain of Ponds

From the Stop Point, continue to turn right onto Gorge Road. Turn left onto Corkscrew Road and continue to the stage start of Corkscrew Plus.

SS14 - Corkscrew Plus

From the Stop Point, continue on Montacute Road towards the CBD. Turn left onto St. Bernards Road. Turn left onto Magill Road. Turn left onto (New) Norton Summit Road and continue to the stage start of Norton Summit.

SS15 & SS19 - Norton Summit 1 & 2

From the Stop Point, continue into Norton Summit, and turn right onto Old Norton Summit Road. Continue towards Adelaide CBD. Turn around at Horsnell Gully Road, and meet the stage start of Old Norton Summit.

SS6 & SS10 - Old Norton Summit 1 & 2

From the Stop Point, continue around to the right on Lobethal Road. Turn left onto Marble Hill Road. Turn right onto Pound Road, and continue to the stage start of Knotts Range.

SS16 - Knotts Range

From the Stop Point, continue to the next junction, and turn right onto Greenhill Road. Turn left onto Rangeview Drive. Turn left onto Carey Gully Road. Re-join the South Eastern Freeway up-track on the left. Take the Mt. Barker exit, and turn right into Mt. Barker. Continue towards Wistow and turn right here towards Strathalbyn. At the roundabout, continue straight ahead onto North Parade. Turn right across the bridge (North Parade), and then turn left onto Commercial Road. Turn left onto Albyn Street, and then turn right onto Catherine Street. Continue to the stage start of the Strathalbyn Town Stage.

SS25 & SS27 - Strathalbyn Town Stage

From the Stop Point, continue on this road to the roundabout. Continue straight through the roundabout onto Adelaide Road. Turn left onto Strathalbyn Road towards Macclesfield. Continue to the stage start of Doctors Creek.

SS26 & SS28 - Macclesfield

From the stop point, continue through Macclesfield, Flaxley, Echunga, Mylor, and Aldgate into Stirling. Continue to the South Eastern Freeway, keeping left towards Adelaide. Continue into Adelaide.



ADELAIDE RALLY
• 2024 •

**2024 SHANNONS
ADELAIDE RALLY**
NOVEMBER 8-10



DAY 1

ADELAIDE RALLY • 2024 •

**Day 1 - Friday
8th Nov. 2024**



2024 Shannons Adelaide Rally

Friday, 8th November, 2024

Section:	TC/SS	Label	E	L	R	RV	Comp KM	Liaison KM	Section Total	Target Time	First Car	
		0	Depart Parc Ferme									8:30
1	1							9.27	9.27	0:25		
	SS 1	Beaumont					1.13				8:55	
	2							4.72	5.85	0:08		
	SS 2	Eagle on the Hill					3.80				9:03	
	2A	Regroup A - Bridgewater In	E					15.62	19.42	0:22	9:25	
2	2B	Regroup A - Bridgewater Out								0:30	9:55	
	3							17.49	17.49	0:18		
	SS 3	Knotts Hill 1			R		3.46				10:13	
	4							1.07	4.53	0:07		
	SS 4	Cherryville Plus 1			R		19.44				10:20	
			Prima Tour Lunch						17.52	36.96	0:45	
	5							15.48	34.92	0:40		
	SS 5	Vista 1					2.60				11:00	
	5A	Regroup B - Foxfield In	E	L				11.59	14.19	0:15	11:15	
3	5B	Regroup B - Foxfield Out								1:30	12:45	
	6							8.14	8.14	0:08		
	SS 6	Old Norton Summit 1			R		3.07				12:53	
	7							3.98	7.05	0:12		
	SS 7	Cherryville Plus 2					19.44				13:05	
	8							7.30	26.74	0:30		
	SS 8	Stafford Hillclimb					2.53				13:35	
	8A	Regroup C - Bridgewater In	E					20.84	23.37	0:30	14:05	
4	8B	Regroup C - Bridgewater Out								0:45	14:50	
	9							17.49	17.49	0:18		
	SS 9	Knotts Hill 2					3.46				15:08	
	10							12.62	16.08	0:16		
	SS 10	Old Norton Summit 2					3.07				15:24	
	10A	Regroup D - Woods Hill In						4.85	7.92	0:10	15:34	
5	10B	Regroup D - Woods Hill Out								0:05	15:39	
	11							0.45	0.45	0:05		
	SS 11	Summit Road					1.64				15:44	
	11A	Arrive Parc Ferme						19.61	21.25	0:30	16:14	
DAILY TOTAL							63.64	170.07	233.71			





'E' indicates entry to regroup or parc ferme without penalty.

'L' indicates designated lunch stop.

'R' indicates this stage is repeated on this day.

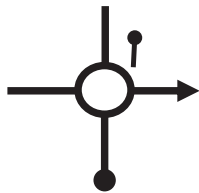
'RV' indicates this stage is reversed on this day.

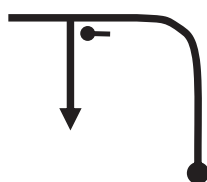
Day 1 Section 1	Your Start Time : : :	Time Allowed 0:25:00	Due Time @ TC : : :		Total Distance	9.27 km
TC 0 TC 1	Adelaide Showgrounds Hayward Drive				Time Allowed	0:25:00 mins
LIAISON ONLY					Average Speed	22.25 km/h
Distance		Direction	Information	Distance To Go		
Total	Part					
0.00	0.00	 1	 TC Out then 30m TL @ XR 	9.27		
0.37	0.37	 2	TL @ TJ	8.90		
1.10	0.73	 3	TR @ XR 	8.17		
FMR along Greenhill Road, crossing over Glen Osmond Road, Fullarton Road and Portrush Road until you reach Devereux Road.						
6.82	5.72	 4	TR 	2.45		
7.49	0.67	 5	SO @ Roundabout FMR	1.78		

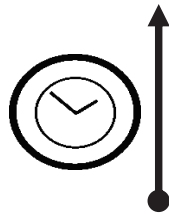
Day 1 Section 1	Your Start Time : : :	Time Allowed 0:25:00	Due Time @ TC : : :		Total Distance	9.27 km
TC 0 TC 1	Adelaide Showgrounds Hayward Drive				Time Allowed	0:25:00 mins
LIAISON ONLY					Average Speed	22.25 km/h
Distance		Direction	Information	Distance To Go		
Total	Part					
8.26	0.77	 6	TR @ Roundabout 	1.01		
8.46	0.20	 7	RGL then 100m TL (Hard to See) 	0.81		
8.95	0.49	 8	SO KL around Tree	0.32		
9.27	0.32	 9	TC In then 30m Start	0.00		

Day 1	Your Start Time	Time Allowed	Due Time @ TC			
Section 1	: : :	0:08:00	: : :			
TC 1	Hayward Drive				Total Distance	5.85 km
TC 2	Mount Barker Road				SS Distance	1.13 km
					Time Allowed	0:08:00 mins
SS 1 - Beaumont					Average Speed	43.88 km/h

Distance		Direction	Information	Distance To Go
Total	Part			

SS1 BEAUMONT

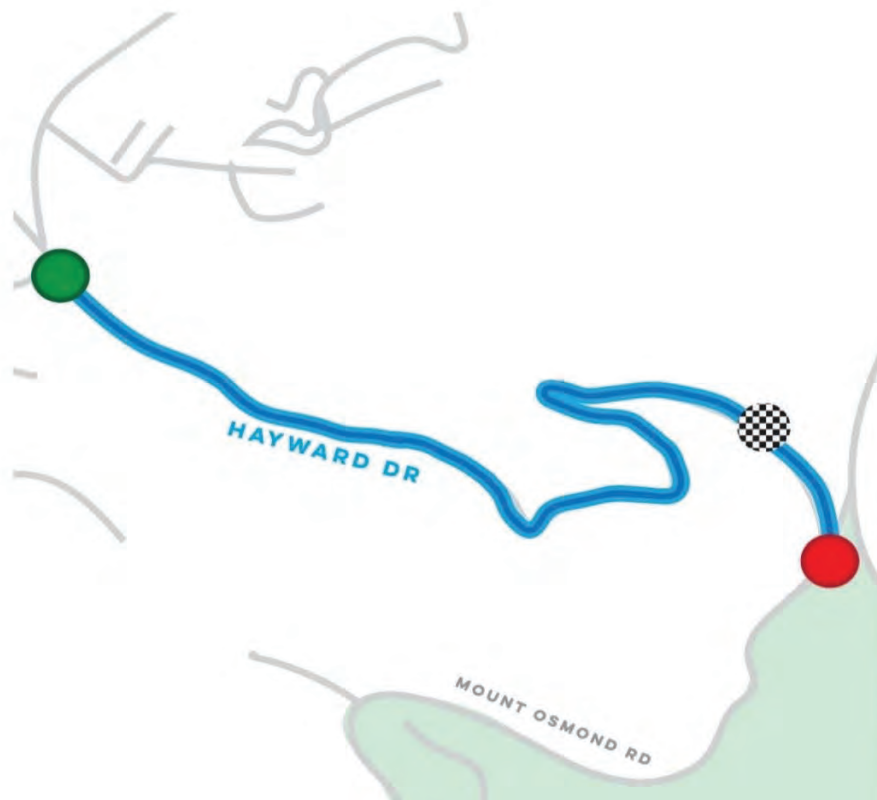











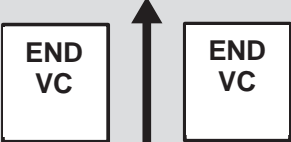

NOTE FOR COMPETITIVE CATEGORIES:

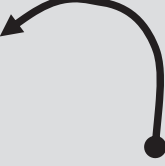

***A minimum elapsed time applies to this stage,
as per the Schedule of Target Times.***

Also note the following excerpt from the RSR-NR:

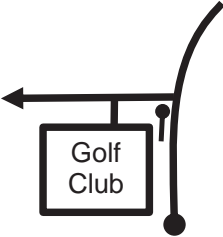
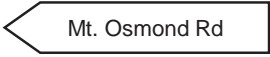
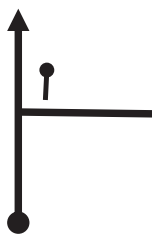
"Any breach of this time on this Special Stage will result in a 30 second penalty being applied. At no time can a vehicle slow to below 30kph or stop, unless being passed by another vehicle, in order to record a time greater than the minimum time. If a vehicle is found to have breached this requirement on this Special Stage this will result in a 30 second penalty being applied."

Day 1	Your Start Time	Time Allowed	Due Time @ TC		Total Distance	5.85 km
Section 1	: : :	0:08:00	: : :		SS Distance	1.13 km
TC 1	Hayward Drive				Time Allowed	0:08:00 mins
TC 2	Mount Barker Road				Average Speed	43.88 km/h
SS 1 - Beaumont						
Distance		Direction	Information	Distance To Go		
Total	Part					
0.00	0.00	 1 1.13	  Start S 34° 57.347 E 138° 39.507	5.85		
0.03	0.03	 2 1.10	Slow Point S 34° 57.362 E 138° 39.524	5.82		
0.22	0.19	 3 0.91	Start VC S 34° 57.415 E 138° 39.623	5.63		
0.42	0.20	 4 0.71	End VC S 34° 57.446 E 138° 39.749	5.43		
0.54	0.12	 5 0.59	! Care RGL S 34° 57.491 E 138° 39.808	5.31		
0.69	0.15	 6 0.44	RGL	5.16		

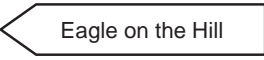
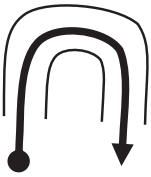
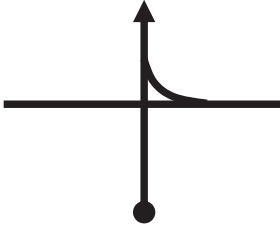
Day 1	Your Start Time	Time Allowed	Due Time @ TC			
Section 1	: : :	0:08:00	: : :		Total Distance	5.85 km
TC 1	Hayward Drive				SS Distance	1.13 km
TC 2	Mount Barker Road				Time Allowed	0:08:00 mins
SS 1 - Beaumont					Average Speed	43.88 km/h
Distance		Direction	Information	Distance To Go		
Total	Part					
0.88	0.19	 7 0.25	Hairpin Right Keep in on Exit	4.97		
1.13	0.25	 8 0.00	Flying Finish S 34° 57.442 E 138° 39.974	4.72		
1.32	0.19	 9	Stop Point S 34° 57.519 E 138° 40.013	4.53		
FMR towards South Eastern Freeway						
2.71	1.39	 10	TL 	3.14		
4.57	1.86	 11	SO Continue onto Freeway on-ramp 	1.28		
Merge onto South Eastern Freeway and Keep Left.						

Day 1	Your Start Time	Time Allowed	Due Time @ TC			
Section 1	: : :	0:08:00	: : :		Total Distance	5.85 km
TC 1	Hayward Drive				SS Distance	1.13 km
TC 2	Mount Barker Road				Time Allowed	0:08:00 mins
SS 1 - Beaumont					Average Speed	43.88 km/h
Distance		Direction	Information	Distance To Go		
Total	Part					
5.18	0.61	 12	Take Freeway exit on L 	0.67		
5.69	0.51	 13	RGR through Tunnel	0.16		
5.75	0.06	 14	SO @ XR	0.10		
5.85	0.10	 15	TC In then 30m Start	0.00		





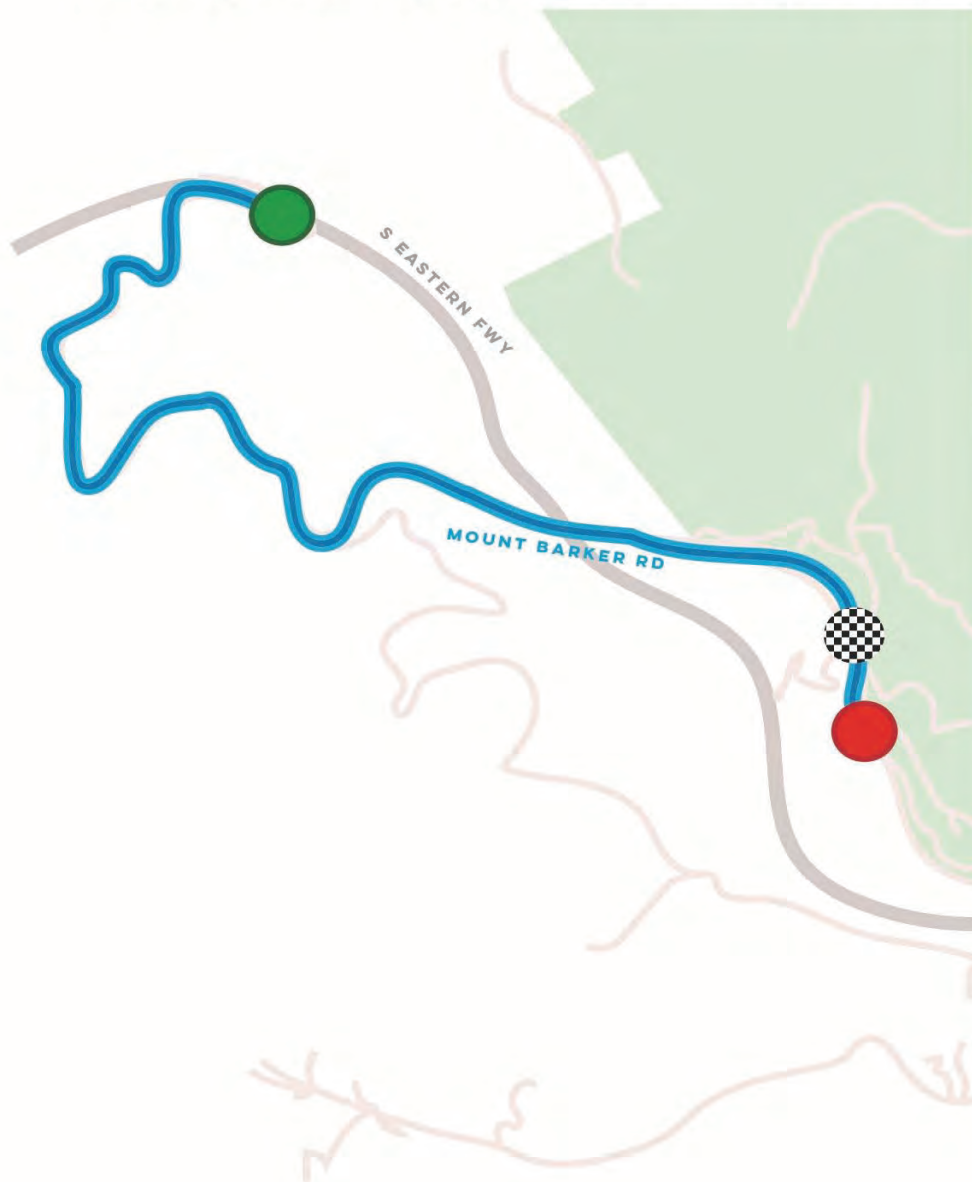

Day 1	Your Start Time	Time Allowed	Due Time @ TC			
Section 1	: : :	0:22:00	: : :		Total Distance	19.42 km
TC 2	Mount Barker Road				SS Distance	3.80 km
TC 2A	Bridgewater Oval				Time Allowed	0:22:00 mins
SS 2 - Eagle on the Hill					Average Speed	52.96 km/h

Distance		Direction	Information	Distance To Go
Total	Part			





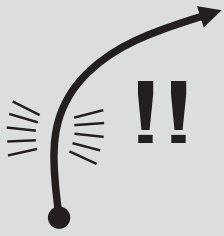

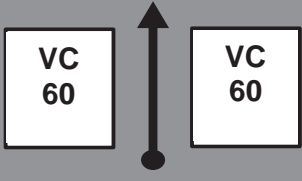
SS2



EAGLE ON THE HILL

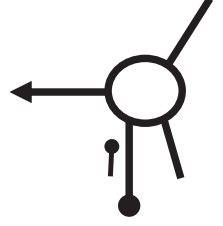
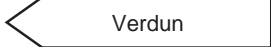
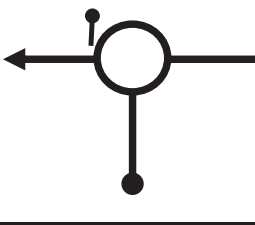

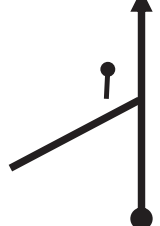



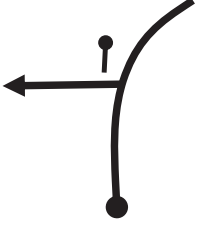

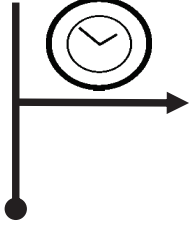

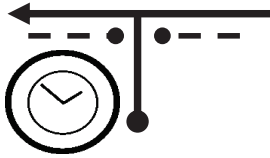



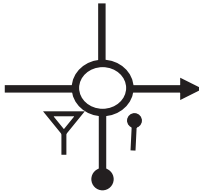

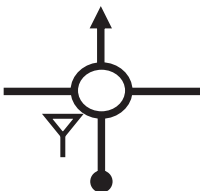
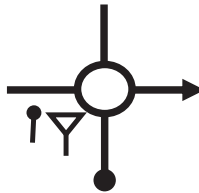



Day 1	Your Start Time	Time Allowed	Due Time @ TC			
Section 1	: : :	0:22:00	: : :		Total Distance	19.42 km
TC 2	Mount Barker Road				SS Distance	3.80 km
TC 2A	Bridgewater Oval				Time Allowed	0:22:00 mins
SS 2 - Eagle on the Hill					Average Speed	52.96 km/h
Distance		Direction	Information	Distance To Go		
Total	Part					
0.00	0.00	 1 3.80	  Start S 34° 58.086 E 138° 40.227	19.42		
0.20	0.20	 2 3.60	RGL	19.22		
1.70	1.50	 3 2.10	 !! Caution Crest then RGR S 34° 58.347 E 138° 40.124	17.72		
3.19	1.49	 4 0.61	Start VC S 34° 58.549 E 138° 40.876	16.23		

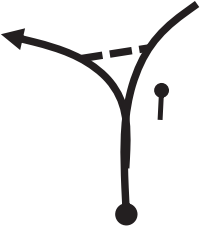

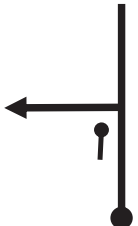
Day 1	Your Start Time	Time Allowed	Due Time @ TC		Total Distance	19.42 km
Section 1	: : :	0:22:00	: : :		SS Distance	3.80 km
TC 2	Mount Barker Road				Time Allowed	0:22:00 mins
TC 2A	Bridgewater Oval				Average Speed	52.96 km/h
SS 2 - Eagle on the Hill						
Distance		Direction	Information	Distance To Go		
Total	Part					
3.39	0.20	<p>5 0.41</p>	<p>End VC</p> <p>S 34° 58.559 E 138° 41.005</p>	16.03		
3.48	0.09	<p>6 0.32</p>	<p>TL into Carpark</p>	15.94		
3.58	0.10	<p>7 0.22</p>	<p>RGR then RGL onto Main Road</p>	15.84		
3.80	0.22	<p>8 0.00</p>	<p>Flying Finish</p> <p>S 34° 58.679 E 138° 41.191</p>	15.62		
4.00	0.20	<p>9 0.00</p>	<p>Stop Point</p> <p>S 34° 58.790 E 138° 41.204</p>	15.42		
4.48	0.48	<p>10 0.00</p>	<p>Continue onto Freeway On Ramp</p>	14.94		

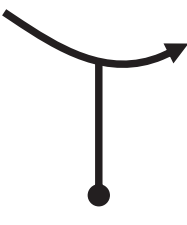
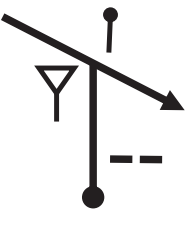
Day 1	Your Start Time	Time Allowed	Due Time @ TC			
Section 1	: : :	0:22:00	: : :		Total Distance	19.42 km
TC 2	Mount Barker Road				SS Distance	3.80 km
TC 2A	Bridgewater Oval				Time Allowed	0:22:00 mins
SS 2 - Eagle on the Hill					Average Speed	52.96 km/h
Distance		Direction	Information	Distance To Go		
Total	Part					
5.29	0.81	 11	! Care Merge onto Freeway	14.13		
Continue on the South Eastern Freeway, passing Crafers, Stirling and Bridgewater. Continue towards Hahndorf.						
15.30	10.01	 12	BL on Freeway Off Ramp 	4.12		
15.93	0.63	 13	TL @ Roundabout 	3.49		
16.46	0.53	 14	TL @ Roundabout 	2.96		
18.96	2.50	 15	SO 	0.46		

Day 1	Your Start Time	Time Allowed	Due Time @ TC			
Section 1	: : :	0:22:00	: : :		Total Distance	19.42 km
TC 2	Mount Barker Road				SS Distance	3.80 km
TC 2A	Bridgewater Oval				Time Allowed	0:22:00 mins
SS 2 - Eagle on the Hill					Average Speed	52.96 km/h
Distance		Direction	Information	Distance To Go		
Total	Part					
19.37	0.41	 16	<p>TL</p> 	0.05		
19.42	0.05	 17	<p>TR then TC In</p>	0.00		

Day 1	Your Start Time	Time Allowed	Due Time @ TC		Total Distance	17.49 km
Section 2	: : :	0:18:00	: : :			
TC 2B	Bridgewater Oval					
TC 3	Hunters Road				Time Allowed	0:18:00 mins
LIAISON ONLY					Average Speed	58.30 km/h
Distance		Direction	Information	Distance To Go		
Total	Part					
0.00	0.00	 <p>1</p>	 TC Out TL thru Gate	17.49		
0.04	0.04	 <p>2</p>	TL @ TJ	17.45		
0.15	0.11	 <p>3</p>	SO 	17.34		
2.34	2.19	 <p>4</p>	GIVE WAY then TR @ Roundabout 	15.15		
4.50	2.16	 <p>5</p>	GIVE WAY then SO @ Roundabout	12.99		
4.86	0.36	 <p>6</p>	GIVE WAY then TR @ Roundabout 	12.63		



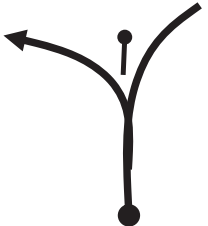
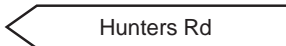
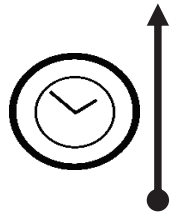

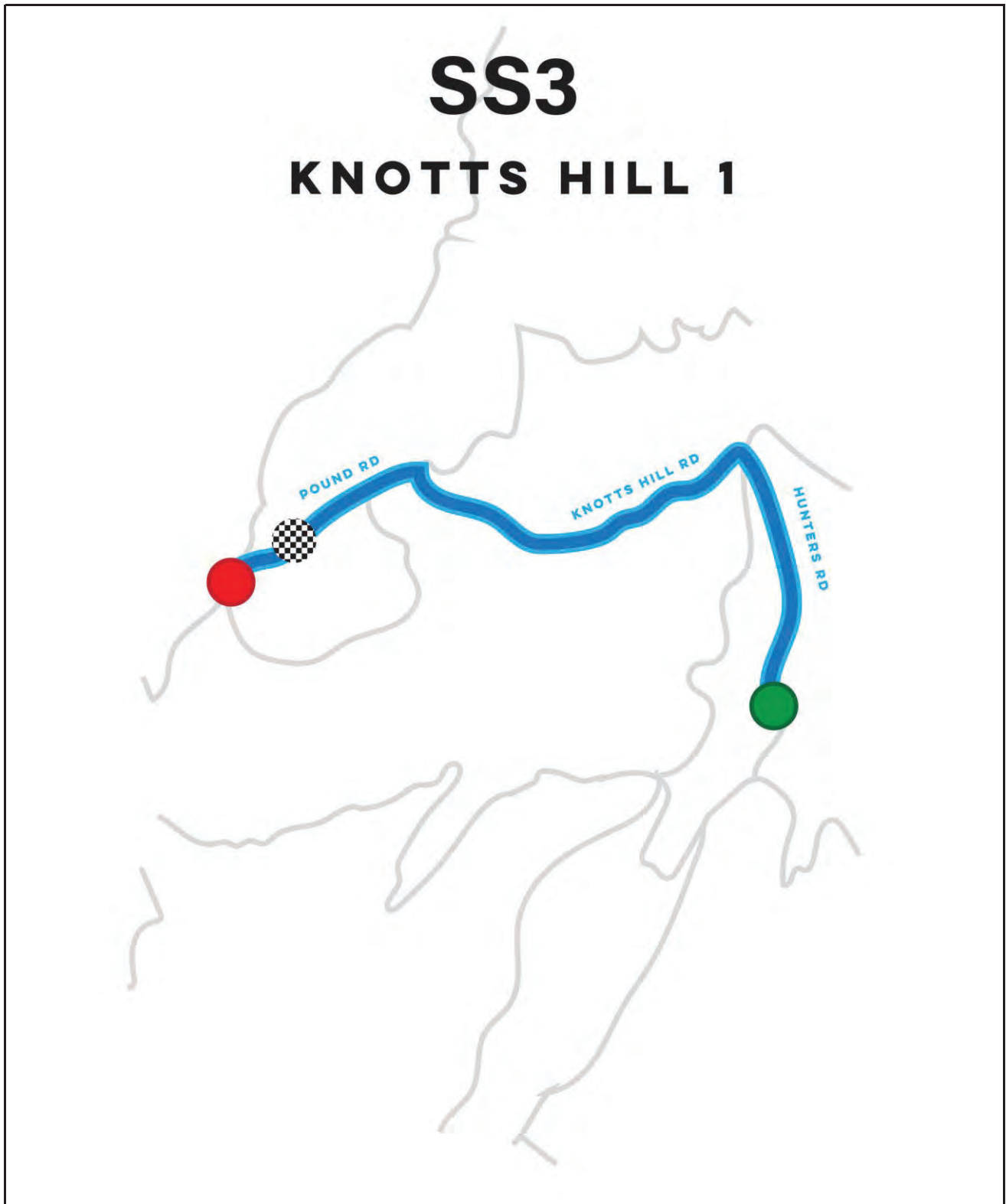

Day 1	Your Start Time	Time Allowed	Due Time @ TC		Total Distance	17.49 km
Section 2	: : :	0:18:00	: : :			
TC 2B	Bridgewater Oval					
TC 3	Hunters Road				Time Allowed	0:18:00 mins
LIAISON ONLY					Average Speed	58.30 km/h
Distance		Direction	Information	Distance To Go		
Total	Part					
5.95	1.09	 7	GIVE WAY then TL @ TJ  then 50m TR 	11.54		
6.61	0.66	 8	TL 	10.88		
7.85	1.24	 9	TL 	9.64		
9.25	1.40	 10	TR @ TJ FMR	8.24		
12.70	3.45	 11	GIVE WAY then TR @ TJ 	4.79		
13.95	1.25	 12	TL 	3.54		

Day 1	Your Start Time	Time Allowed	Due Time @ TC		Total Distance	17.49 km
Section 2	: : :	0:18:00	: : :			
TC 2B	Bridgewater Oval					
TC 3	Hunters Road				Time Allowed	0:18:00 mins
LIAISON ONLY					Average Speed	58.30 km/h
Distance		Direction	Information	Distance To Go		
Total	Part					
16.76	2.81	 13	STOP then TR @ TJ Hard to See 	0.73		
17.18	0.42	 14	TL 	0.31		
17.49	0.31	 15	TC In then 30m Start	0.00		

Day 1	Your Start Time	Time Allowed	Due Time @ TC			
Section 2	: :	0:07:00	: :		Total Distance	4.53 km
TC 3	Hunters Road				SS Distance	3.46 km
TC 4	Marble Hill Road				Time Allowed	0:07:00
SS 3 - Knotts Hill 1					Average Speed	38.83 km/h

Distance		Direction	Information	Distance To Go
Total	Part			

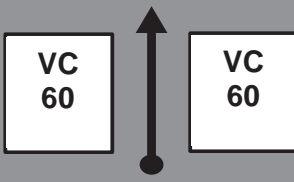
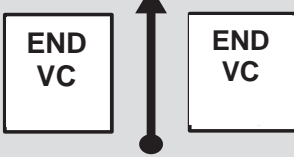
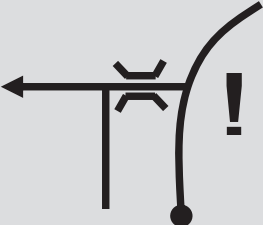



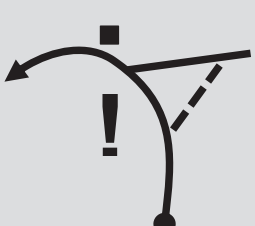
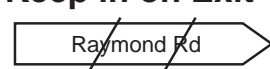
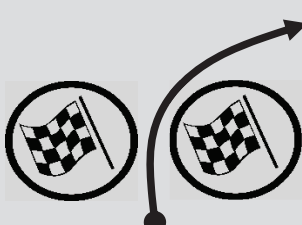
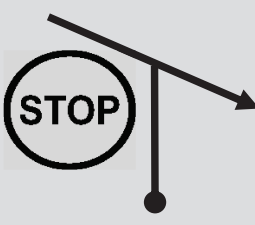
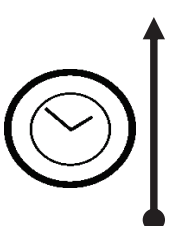





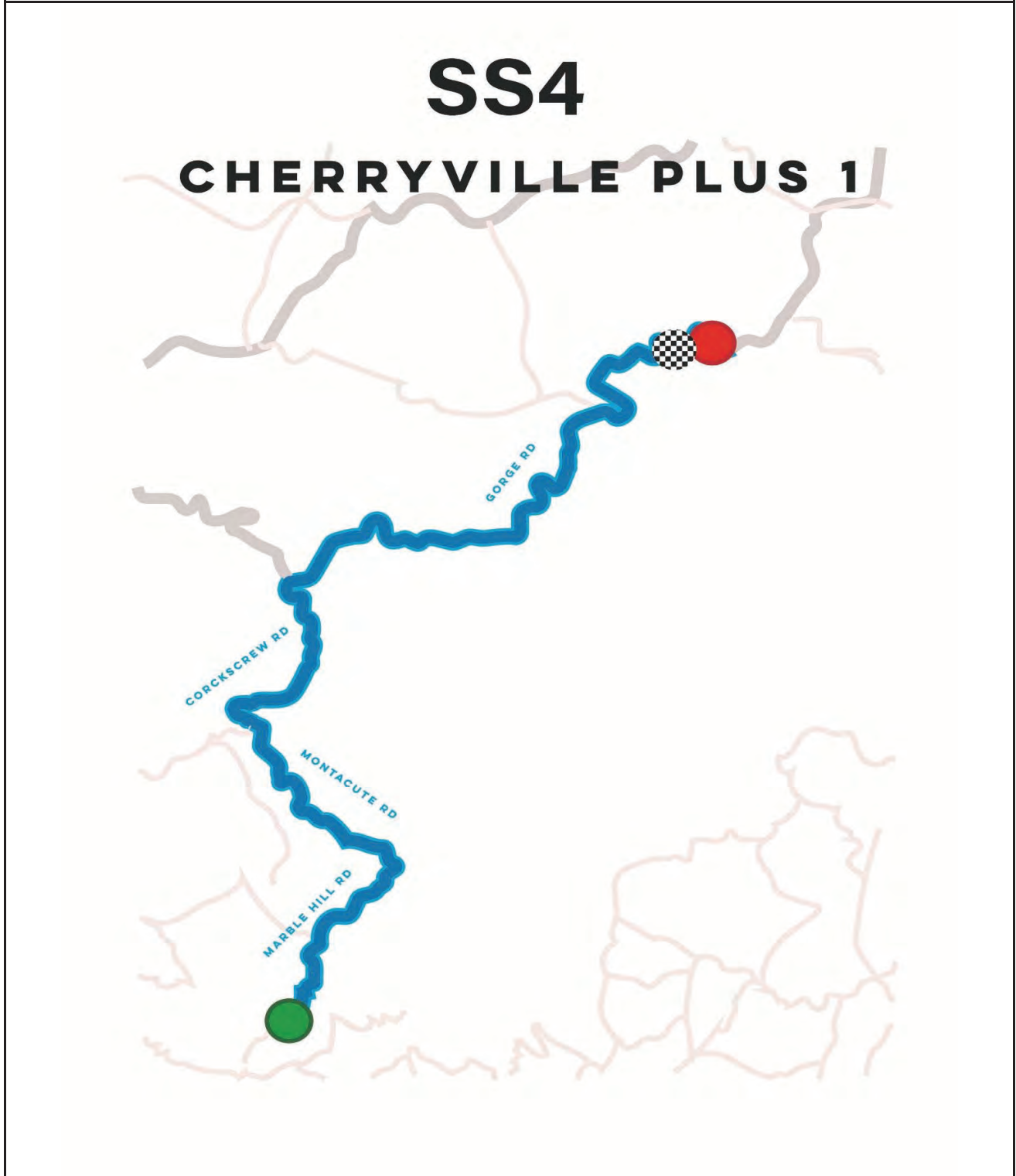

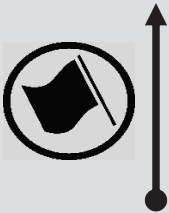
Day 1	Your Start Time	Time Allowed	Due Time @ TC		Total Distance	4.53 km
Section 2	: :	0:07:00	: :		SS Distance	3.46 km
TC 3	Hunters Road				Time Allowed	0:07:00
TC 4	Marble Hill Road				Average Speed	38.83 km/h
SS 3 - Knotts Hill 1						
Distance		Direction	Information	Distance To Go		
Total	Part					
0.00	0.00	 1 3.46	  Start S 34° 56.233 E 138° 46.232	4.53		
0.37	0.37	 2 3.09	! Care RGL on Crest S 34° 56.047 E 138° 46.244	4.16		
0.76	0.39	 3 2.70	Start VC S 34° 55.848 E 138° 46.227	3.77		
0.96	0.20	 4 2.50	End VC S 34° 55.741 E 138° 46.173	3.57		
1.14	0.18	 5 2.32	! Care TL onto Bridge then SO S 34° 55.664 E 138° 46.134	3.39		
1.98	0.84	 6 1.48	RGL then 30m RGR	2.55		

Day 1	Your Start Time	Time Allowed	Due Time @ TC			
Section 2	: :	0:07:00	: :		Total Distance	4.53 km
TC 3	Hunters Road				SS Distance	3.46 km
TC 4	Marble Hill Road				Time Allowed	0:07:00
SS 3 - Knotts Hill 1					Average Speed	38.83 km/h
Distance		Direction	Information	Distance To Go		
Total	Part					
2.33	0.35	 <p>7 1.13</p>	RGR then 30m RGL	2.20		
2.82	0.49	 <p>8 0.64</p>	! Care RGL then Tightens Keep in on Exit  S 34° 55.709 E 138° 45.245	1.71		
3.46	0.64	 <p>9 0.00</p>	Flying Finish S 34° 55.852 E 138° 44.890	1.07		
3.75	0.29	 <p>10</p>	Stop Point then 20m TR @ TJ S 34° 55.941 E 138° 44.705	0.78		
4.53	0.78	 <p>11</p>	TC In then 30m Start	0.00		

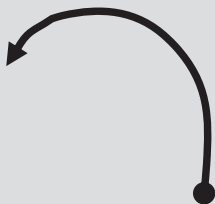



Day 1	Your Start Time	Time Allowed	Due Time @ TC			
Section 2	: : :	0:40:00	: : :		Total Distance	34.92 km
TC 4	Marble Hill Road				SS Distance	19.44 km
TC 5	Lower North East Road				Time Allowed	0:40:00 mins
SS 4 - Cherryville Plus 1					Average Speed	52.38 km/h



Distance		Direction	Information	Distance To Go
Total	Part			



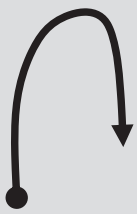
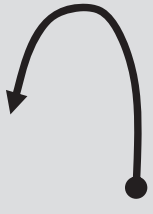
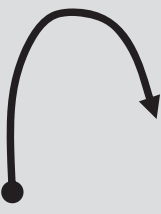

Day 1	Your Start Time	Time Allowed	Due Time @ TC		Total Distance	34.92 km
Section 2	: : :	0:40:00	: : :		SS Distance	19.44 km
TC 4	Marble Hill Road				Time Allowed	0:40:00 mins
TC 5	Lower North East Road				Average Speed	52.38 km/h
SS 4 - Cherryville Plus 1						
Distance		Direction	Information	Distance To Go		
Total	Part					
0.00	0.00	 1 19.44	   Start S 34° 55.569 E 138° 44.835	34.92		
1.05	1.05	 2 18.39	RGL then RGR	33.87		
1.93	0.88	 3 17.51	RGL then Tightens	32.99		
2.34	0.41	 4 17.10	SO @ XR then 70m RGR on Crest 	32.58		
2.68	0.34	 5 16.76	KL Road Narrows 	32.24		
3.03	0.35	 6 16.41	! Care Crest then RGL S 34° 54.452 E 138° 45.820	31.89		

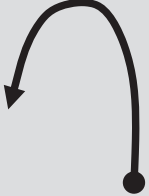
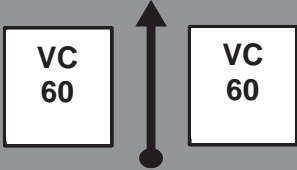
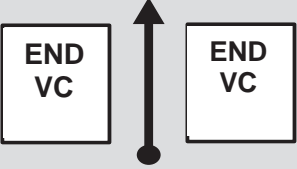
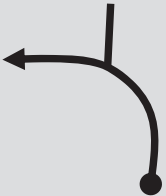

Day 1	Your Start Time	Time Allowed	Due Time @ TC			
Section 2	: : :	0:40:00	: : :		Total Distance	34.92 km
TC 4	Marble Hill Road				SS Distance	19.44 km
TC 5	Lower North East Road				Time Allowed	0:40:00 mins
SS 4 - Cherryville Plus 1					Average Speed	52.38 km/h
Distance		Direction	Information	Distance To Go		
Total	Part					
3.28	0.25	<p>7 16.16</p>	<p>RGL Keep in on Exit</p>	31.64		
3.38	0.10	<p>8 16.06</p>	<p>!! Caution RGR</p> <p>S 34° 54.331 E 138° 45.958</p>	31.54		
4.11	0.73	<p>9 15.33</p>	<p>Start VC</p> <p>S 34° 54.092 E 138° 45.793</p>	30.81		
4.16	0.05	<p>10 15.28</p>	<p>RGR then 70m RGL over Crest</p>	30.76		
4.31	0.15	<p>11 15.13</p>	<p>End VC then RGR</p> <p>S 34° 54.061 E 138° 45.667</p>	30.61		
5.13	0.82	<p>12 14.31</p>	<p>RGR</p>	29.79		

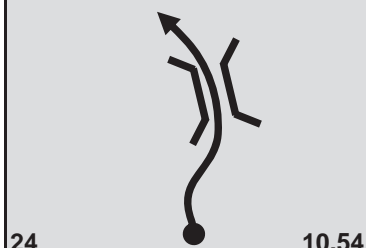
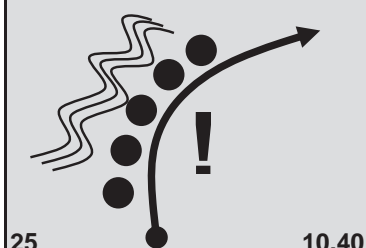
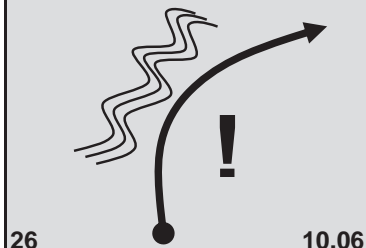
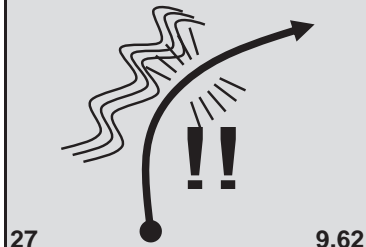
Day 1	Your Start Time	Time Allowed	Due Time @ TC			
Section 2	: : :	0:40:00	: : :		Total Distance	34.92 km
TC 4	Marble Hill Road				SS Distance	19.44 km
TC 5	Lower North East Road				Time Allowed	0:40:00 mins
SS 4 - Cherryville Plus 1					Average Speed	52.38 km/h
Distance		Direction	Information	Distance To Go		
Total	Part					
5.65	0.52	 13 13.79	Hairpin Right	29.27		
6.26	0.61	 14 13.18	RGHR	28.66		
6.43	0.17	 15 13.01	TR then RGL SOS A S 34° 53.285 E 138° 44.946 	28.49		
7.28	0.85	 16 12.16	Very Tight Hairpin Right	27.64		
7.42	0.14	 17 12.02	Hairpin Left	27.50		
7.45	0.03	 18 11.99	Hairpin Right	27.47		

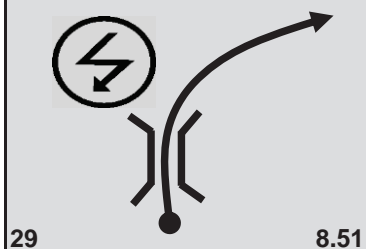
Day 1	Your Start Time	Time Allowed	Due Time @ TC			
Section 2	: : :	0:40:00	: : :		Total Distance	34.92 km
TC 4	Marble Hill Road				SS Distance	19.44 km
TC 5	Lower North East Road				Time Allowed	0:40:00 mins
SS 4 - Cherryville Plus 1					Average Speed	52.38 km/h
Distance		Direction	Information	Distance To Go		
Total	Part					
7.55	0.10	 19 11.89	Hairpin Left	27.37		
7.95	0.40	 20 11.49	Start VC S 34° 53.029 E 138° 45.039	26.97		
8.15	0.20	 21 11.29	End VC S 34° 53.012 E 138° 45.161	26.77		
8.18	0.03	 22 11.26	RGL	26.74		
8.53	0.35	 23 10.91	RGL	26.39		

Day 1	Your Start Time	Time Allowed	Due Time @ TC		Total Distance	34.92 km
Section 2	: :	0:40:00	: :		SS Distance	19.44 km
TC 4	Marble Hill Road				Time Allowed	0:40:00 mins
TC 5	Lower North East Road				Average Speed	52.38 km/h
SS 4 - Cherryville Plus 1						
Distance		Direction	Information	Distance To Go		
Total	Part					
8.90	0.37		Narrow Bridge	26.02		
9.04	0.14		! Care RGR Rocks & Creek on L S 34° 52.594 E 138° 45.340	25.88		
9.38	0.34		! Care RGR Creek on L S 34° 52.434 E 138° 45.286	25.54		
9.82	0.44		RGR Long then !! Caution Tightens and Continues over Crest S 34° 52.289 E 138° 45.224	25.10		
10.12	0.30		 TR @ TJ !! Caution Drop Ahead S 34° 52.185 E 138° 45.164	24.80		
10.93	0.81		Bridge then RGR SOS B S 34° 51.888 E 138° 45.514	23.99		

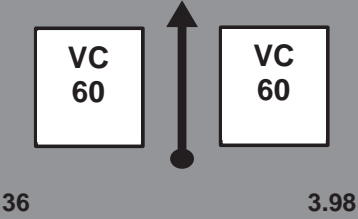
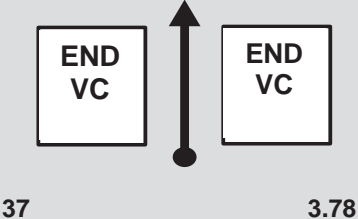
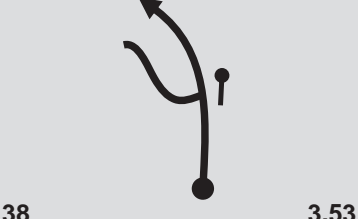
Day 1	Your Start Time	Time Allowed	Due Time @ TC			
Section 2	: : :	0:40:00	: : :		Total Distance	34.92 km
TC 4	Marble Hill Road				SS Distance	19.44 km
TC 5	Lower North East Road				Time Allowed	0:40:00 mins
SS 4 - Cherryville Plus 1					Average Speed	52.38 km/h
Distance		Direction	Information	Distance To Go		
Total	Part					
13.31	2.38		Start VC S 34° 51.842 E 138° 46.789	21.61		
13.51	0.20		End VC S 34° 51.839 E 138° 46.926	21.41		
13.90	0.39		!! Caution Crest then RGR S 34° 51.704 E 138° 47.056	21.02		
14.48	0.58		!! Caution Crest then RGR Long S 34° 51.529	20.44		
15.11	0.63		Crest then 100m RGR	20.39		
15.74	0.63		!! Caution RGR on Crest S 34° 51.061 E 138° 47.465	19.81		

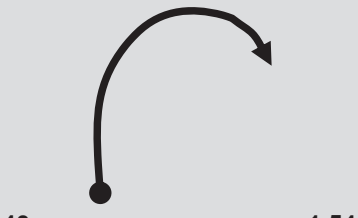
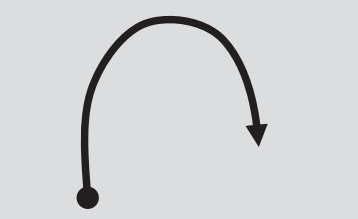
Day 1	Your Start Time	Time Allowed	Due Time @ TC			
Section 2	: : :	0:40:00	: : :		Total Distance	34.92 km
TC 4	Marble Hill Road				SS Distance	19.44 km
TC 5	Lower North East Road				Time Allowed	0:40:00 mins
SS 4 - Cherryville Plus 1					Average Speed	52.38 km/h
Distance		Direction	Information	Distance To Go		
Total	Part					
16.09	0.35		Start VC S 34° 50.969 E 138° 47.595	19.46		
16.29	0.20		End VC S 34° 50.930 E 138° 47.724	19.26		
16.54	0.25		SO FMR 	19.01		
17.53	0.99		! Care RGR and Tightens S 34° 50.603 E 138° 47.744	18.02		
18.53	1.00		RGHR	17.02		
19.21	0.68		RGHR and tightens	16.34		

Day 1	Your Start Time	Time Allowed	Due Time @ TC		Total Distance	34.92 km
Section 2	: : :	0:40:00	: : :		SS Distance	19.44 km
TC 4	Marble Hill Road				Time Allowed	0:40:00 mins
TC 5	Lower North East Road				Average Speed	52.38 km/h
SS 4 - Cherryville Plus 1						
Distance		Direction	Information	Distance To Go		
Total	Part					
19.44	0.23	<p>42 0.63</p>	<p>Flying Finish</p> <p>S 34° 50.370 E 138° 48.558</p>	16.11		
19.62	0.18	<p>43</p>	<p>Stop Point then 20m SO</p> <p>S 34° 50.464 E 138° 48.595</p>	15.93		
21.00	1.38	<p>44</p>	<p>TL</p> <p>Williamstown</p>	14.55		
23.10	2.10	<p>45</p>	<p>TL @ TJ</p> <p>Tea Tree Gully</p>	12.45		
29.20	6.10	<p>46</p>	<p>SO</p> <p>Paracombe Rd</p> <p>then 70m TL</p> <p>Murray Rd</p>	6.35		
31.94	2.74	<p>47</p>	<p>STOP then TR @ TJ</p>	3.61		











Day 1	Your Start Time	Time Allowed	Due Time @ TC			
Section 2	: : :	0:40:00	: : :		Total Distance	34.92 km
TC 4	Marble Hill Road				SS Distance	19.44 km
TC 5	Lower North East Road				Time Allowed	0:40:00 mins
SS 4 - Cherryville Plus 1					Average Speed	52.38 km/h
Distance		Direction	Information	Distance To Go		
Total	Part					
32.42	0.48	<p>48</p>	KR	3.13		
32.61	0.19	<p>49</p>	KL	2.94		
34.77	2.16	<p>50</p>	<p>TL @ TJ</p>	0.78		
34.92	0.15	<p>51</p>	<p>TC IN then 30m SO @ XR then 30m Start</p>	0.63		

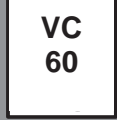

Day 1	Your Start Time	Time Allowed	Due Time @ TC			
Section 2	: : :	0:15:00	: : :		Total Distance	14.19 km
TC 5	Lower North East Road				SS Distance	2.60 km
TC 5A	Foxfield Oval				Time Allowed	0:15:00 mins
SS 5 - Vista 1					Average Speed	56.76 km/h

Distance		Direction	Information	Distance To Go
Total	Part			





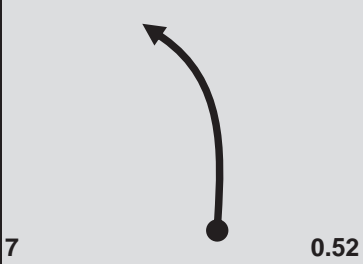
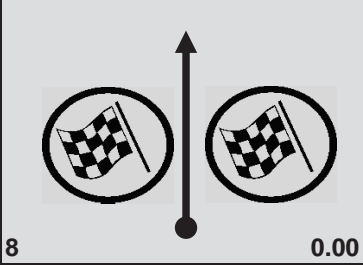
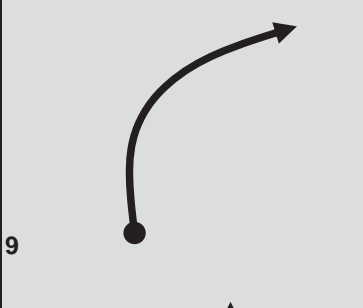
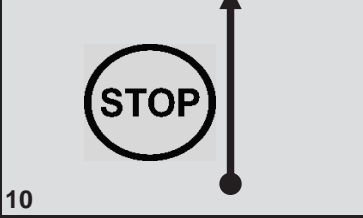
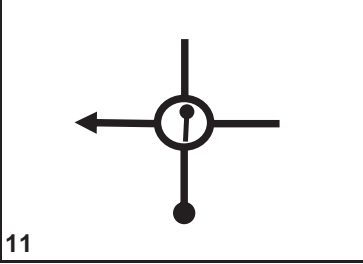

Day 1	Your Start Time	Time Allowed	Due Time @ TC			
Section 2	: : :	0:15:00	: : :		Total Distance	14.19 km
TC 5	Lower North East Road				SS Distance	2.60 km
TC 5A	Foxfield Oval				Time Allowed	0:15:00 mins
SS 5 - Vista 1					Average Speed	56.76 km/h

Distance		Direction	Information	Distance To Go
Total	Part			
0.00	0.00	 <p>1 2.60</p>	  <p>Start S 34° 50.446 E 138° 44.804</p>	14.19
0.78	0.78	 <p>2 1.82</p>	RGL	13.41
0.82	0.04	  <p>3 1.78</p>	 <p>Start VC S 34° 50.419 E 138° 44.285</p>	13.37
1.02	0.20	  <p>4 1.58</p>	<p>End VC S 34° 50.480 E 138° 44.171</p>	13.17
1.36	0.34	 <p>5 1.24</p>	<p>Bump as RGL then 100m !! Caution RGHR S 34° 50.589 E 138° 43.909</p>	12.83
1.80	0.44	 <p>6 0.80</p>	RGL then RGR	12.39

Day 1	Your Start Time	Time Allowed	Due Time @ TC			
Section 2	: : :	0:15:00	: : :		Total Distance	14.19 km
TC 5	Lower North East Road				SS Distance	2.60 km
TC 5A	Foxfield Oval				Time Allowed	0:15:00 mins
SS 5 - Vista 1					Average Speed	56.76 km/h
Distance		Direction	Information	Distance To Go		
Total	Part					
2.08	0.28		RGL	12.11		
2.60	0.52		Flying Finish S 34° 50.261 E 138° 43.576	11.59		
2.87	0.27		RGR	11.32		
3.02	0.15		Stop Point S 34° 50.410 E 138° 43.421	11.17		
3.34	0.32		TL @ Roundabout 	10.85		
FMR to Darley Road, passing over George Street.						

Day 1	Your Start Time	Time Allowed	Due Time @ TC			
Section 2	: : :	0:15:00	: : :			
TC 5	Lower North East Road				Total Distance	14.19 km
TC 5A	Foxfield Oval				SS Distance	2.60 km
SS 5 - Vista 1					Time Allowed	0:15:00 mins
					Average Speed	56.76 km/h
Distance		Direction	Information	Distance To Go		
Total	Part					
9.81	6.47	<p>12</p>	<p>TL @ XR</p> <p>Darley Rd</p>	4.38		
10.18	0.37	<p>13</p>	<p>TL @ XR</p> <p>Gorge Rd</p>	4.01		
12.03	1.85	<p>14</p>	<p>Move to Left lane</p> <p>GIVE WAY then</p> <p>SO @ Roundabout</p>	2.16		
13.04	1.01	<p>15</p>	<p>TR</p> <p>Maryvale Rd</p>	1.15		
14.19	1.15	<p>16</p>	<p>TL into Oval</p> <p>then TC In</p> <p>Follow direction of</p> <p>Officials</p>	0.00		

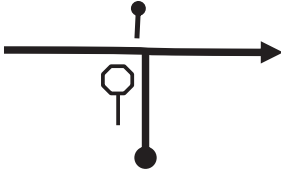
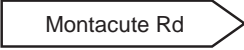
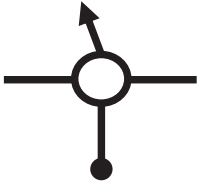
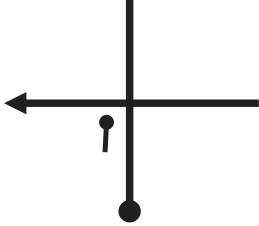
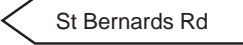
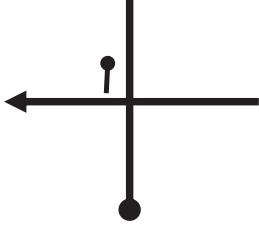
Day 1	Your Start Time	Time Allowed	Due Time @ TC		Total Distance	8.14 km
Section 3	: : :	0:08:00	: : :			
TC 5B	Foxfield Oval					
TC 6	Old Norton Summit Road				Time Allowed	0:08:00 mins
LIAISON ONLY					Average Speed	61.05 km/h

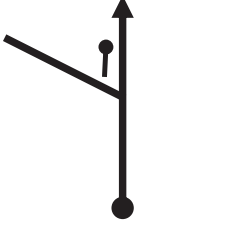
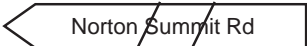
Distance		Direction	Information	Distance To Go
Total	Part			
0.00	0.00	 1	 TC Out TL onto Main Road	8.14
0.52	0.52	 2	STOP then TR @ TJ 	7.62
1.33	0.81	 3	SO @ Roundabout	6.81
3.00	1.67	 4	TL @ XR 	5.14
5.69	2.69	 5	TL @ XR 	2.45
6.14	0.45	 6	SO 	2.00

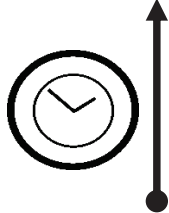
Day 1 Section 3	Your Start Time : : :	Time Allowed 0:08:00	Due Time @ TC : : :		Total Distance	8.14 km
TC 5B	Foxfield Oval					
TC 6	Old Norton Summit Road				Time Allowed	0:08:00 mins
LIAISON ONLY					Average Speed	61.05 km/h
Distance		Direction		Information		Distance To Go
Total	Part					
8.14	2.00			TC In then 30m Start		0.00
		7				





Day 1	Your Start Time	Time Allowed	Due Time @ TC			
Section 3	: : :	0:12:00	: : :		Total Distance	7.05 km
TC 6	Old Norton Summit Road				SS Distance	3.07 km
TC 7	Marble Hill Road				Time Allowed	0:12:00
SS 6 - Old Norton Summit 1					Average Speed	35.25 km/h







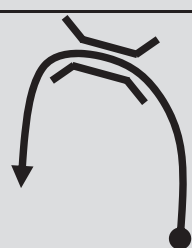
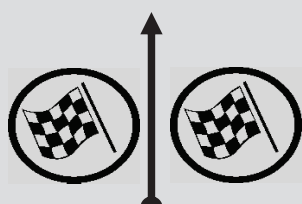
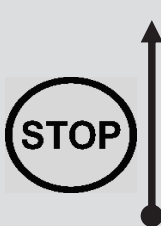

Distance		Direction	Information	Distance To Go
Total	Part			

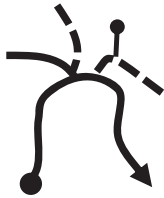
SS6

OLD NORTON SUMMIT 1

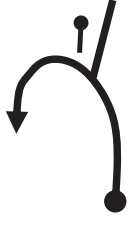

Day 1	Your Start Time	Time Allowed	Due Time @ TC			
Section 3	: : :	0:12:00	: : :		Total Distance	7.05 km
TC 6	Old Norton Summit Road				SS Distance	3.07 km
TC 7	Marble Hill Road				Time Allowed	0:12:00
SS 6 - Old Norton Summit 1					Average Speed	35.25 km/h
Distance		Direction	Information	Distance To Go		
Total	Part					
0.00	0.00	 1 3.07	  Start S 34° 55.291 E 138° 41.907	7.05		
0.04	0.04	 2 3.03	RGL Do Not Cut	7.01		
1.50	1.46	 3 1.57	RGL Do Not Cut	5.55		
2.44	0.94	 4 0.63	Haripin Left over Bridge	4.61		
3.07	0.63	 5 0.00	Flying Finish S 34° 55.484 E 138° 43.334	3.98		
3.37	0.30	 6	Stop Point S 34° 55.385 E 138° 43.456	3.68		

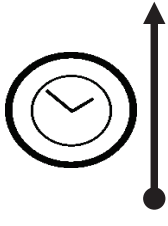





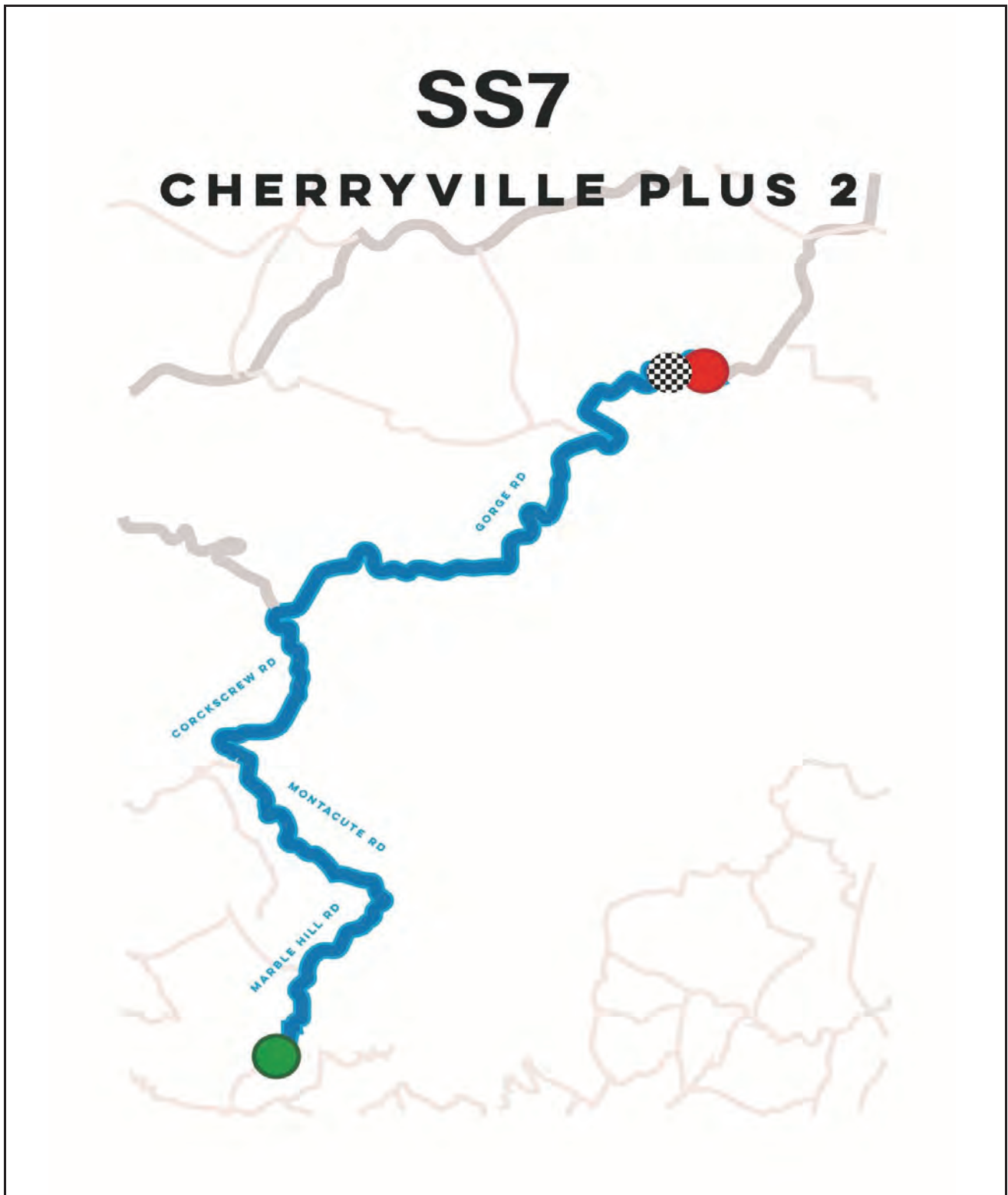

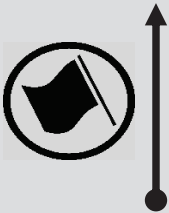

Day 1	Your Start Time	Time Allowed	Due Time @ TC			
Section 3	: : :	0:12:00	: : :		Total Distance	7.05 km
TC 6	Old Norton Summit Road				SS Distance	3.07 km
TC 7	Marble Hill Road				Time Allowed	0:12:00
SS 6 - Old Norton Summit 1					Average Speed	35.25 km/h
Distance		Direction	Information	Distance To Go		
Total	Part					
3.42	0.05	 7	TR FMR 	3.63		
4.36	0.94	 8	KL 	2.69		
5.05	0.69	 9	BL 	2.00		
5.74	0.69	 10	KL then RGL 	1.31		
7.05	1.31	 11	TC In then 30m Start	0.00		

Day 1	Your Start Time	Time Allowed	Due Time @ TC		Total Distance	26.74 km
Section 3	: : :	0:30:00	: : :		SS Distance	19.44 km
TC 7	Marble Hill Road				Time Allowed	0:30:00 mins
TC 8	Fox Creek Road				Average Speed	53.48 km/h
SS 7 - Cherryville Plus 2						

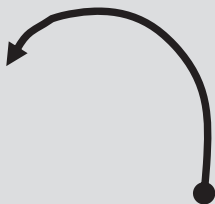

Distance		Direction	Information	Distance To Go
Total	Part			





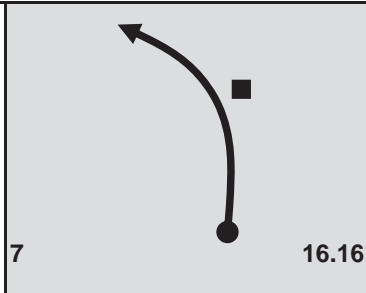

Day 1	Your Start Time	Time Allowed	Due Time @ TC		Total Distance	26.74 km
Section 3	: : :	0:30:00	: : :		SS Distance	19.44 km
TC 7	Marble Hill Road				Time Allowed	0:30:00 mins
TC 8	Fox Creek Road				Average Speed	53.48 km/h
SS 7 - Cherryville Plus 2						

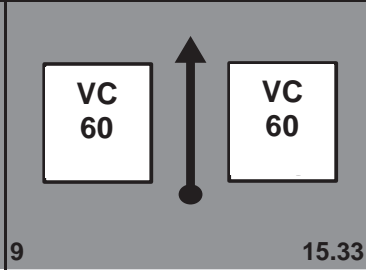
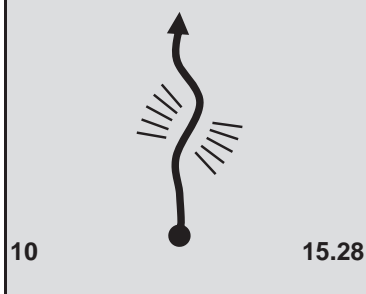
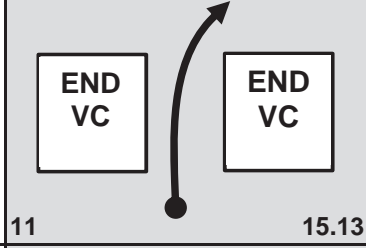
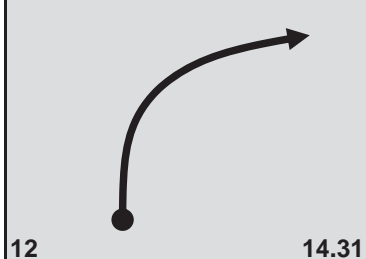

Distance		Direction	Information	Distance To Go
Total	Part			
0.00	0.00	 1 19.44	   Start S 34° 55.569 E 138° 44.835	26.74
1.05	1.05	 2 18.39	RGL then RGR	25.69
1.93	0.88	 3 17.51	RGL then Tightens	24.81
2.34	0.41	 4 17.10	SO @ XR then 70m RGR on Crest 	24.40
2.68	0.34	 5 16.76	KL Road Narrows 	24.06
3.03	0.35	 6 16.41	! Care Crest then RGL S 34° 54.452 E 138° 45.820	23.71

Day 1	Your Start Time	Time Allowed	Due Time @ TC		Total Distance	26.74 km
Section 3	: : :	0:30:00	: : :		SS Distance	19.44 km
TC 7	Marble Hill Road				Time Allowed	0:30:00 mins
TC 8	Fox Creek Road				Average Speed	53.48 km/h
SS 7 - Cherryville Plus 2						

Distance		Direction	Information	Distance To Go
Total	Part			
3.28	0.25	 <p>7 16.16</p>	<p>RGL Keep in on Exit</p>	23.46
3.38	0.10	 <p>8 16.06</p>	<p>!! Caution RGR</p> <p>S 34° 54.331 E 138° 45.958</p>	23.36
4.11	0.73	 <p>9 15.33</p>	<p>Start VC</p> <p>S 34° 54.092 E 138° 45.793</p>	22.63
4.16	0.05	 <p>10 15.28</p>	<p>RGR then 70m RGL over Crest</p>	22.58
4.31	0.15	 <p>11 15.13</p>	<p>End VC then RGR</p> <p>S 34° 54.061 E 138° 45.667</p>	22.43
5.13	0.82	 <p>12 14.31</p>	<p>RGR</p>	21.61

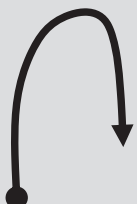
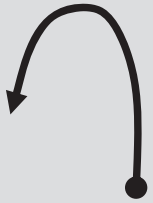
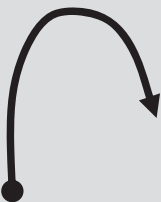
Day 1	Your Start Time	Time Allowed	Due Time @ TC		Total Distance	26.74 km
Section 3	: : :	0:30:00	: : :		SS Distance	19.44 km
TC 7	Marble Hill Road				Time Allowed	0:30:00 mins
TC 8	Fox Creek Road				Average Speed	53.48 km/h
SS 7 - Cherryville Plus 2						

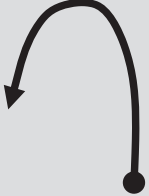
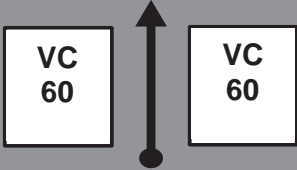
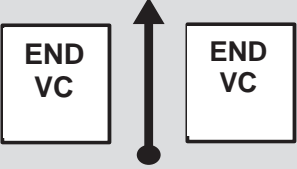
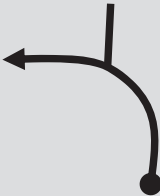
Distance		Direction	Information	Distance To Go
Total	Part			
5.65	0.52	 13 13.79	Hairpin Right	21.09
6.26	0.61	 14 13.18	RGHR	20.48
6.43	0.17	 15 13.01	TR then RGL SOS A S 34° 53.285 E 138° 44.946 	20.31
7.28	0.85	 16 12.16	Very Tight Hairpin Right	19.46
7.42	0.14	 17 12.02	Hairpin Left	19.32
7.45	0.03	 18 11.99	Hairpin Right	19.29

Day 1	Your Start Time	Time Allowed	Due Time @ TC			
Section 3	: : :	0:30:00	: : :		Total Distance	26.74 km
TC 7	Marble Hill Road				SS Distance	19.44 km
TC 8	Fox Creek Road				Time Allowed	0:30:00 mins
SS 7 - Cherryville Plus 2					Average Speed	53.48 km/h
Distance		Direction	Information	Distance To Go		
Total	Part					
7.55	0.10	 19 11.89	Hairpin Left	19.19		
7.95	0.40	 20 11.49	Start VC S 34° 53.029 E 138° 45.039	18.79		
8.15	0.20	 21 11.29	End VC S 34° 53.012 E 138° 45.161	18.59		
8.18	0.03	 22 11.26	RGL	18.56		
8.53	0.35	 23 10.91	RGL	18.21		

Day 1	Your Start Time	Time Allowed	Due Time @ TC			
Section 3	: : :	0:30:00	: : :		Total Distance	26.74 km
TC 7	Marble Hill Road				SS Distance	19.44 km
TC 8	Fox Creek Road				Time Allowed	0:30:00 mins
SS 7 - Cherryville Plus 2					Average Speed	53.48 km/h

Distance		Direction	Information	Distance To Go
Total	Part			
8.90	0.37		<p>Narrow Bridge</p>	17.84
9.04	0.14		<p>! Care</p> <p>RGR Rocks & Creek on L S 34° 52.594 E 138° 45.340</p>	17.70
9.38	0.34		<p>! Care</p> <p>RGR Creek on L S 34° 52.434 E 138° 45.286</p>	17.36
9.82	0.44		<p>RGR Long then !! Caution Tightens and Continues over Crest S 34° 52.289 E 138° 45.224</p>	16.92
10.12	0.30		 <p>TR @ TJ</p> <p>!! Caution Drop Ahead S 34° 52.185 E 138° 45.164</p>	16.62
10.93	0.81		<p>Bridge then RGR</p> <p>SOS B S 34° 51.888 E 138° 45.514</p>	15.81

Day 1	Your Start Time	Time Allowed	Due Time @ TC		Total Distance	26.74 km
Section 3	: : :	0:30:00	: : :		SS Distance	19.44 km
TC 7	Marble Hill Road				Time Allowed	0:30:00 mins
TC 8	Fox Creek Road				Average Speed	53.48 km/h
SS 7 - Cherryville Plus 2						

Distance		Direction	Information	Distance To Go
Total	Part			
13.31	2.38		Start VC S 34° 51.842 E 138° 46.789	13.43
13.51	0.20		End VC S 34° 51.839 E 138° 46.926	13.23
13.90	0.39		!! Caution Crest then RGR S 34° 51.704 E 138° 47.056	12.84
14.48	0.58		!! Caution Crest then RGR Long S 34° 51.529	12.26
15.11	0.63		Crest then 100m RGR	12.21
15.74	0.63		!! Caution RGR on Crest S 34° 51.061 E 138° 47.465	11.63

Day 1	Your Start Time	Time Allowed	Due Time @ TC		Total Distance	26.74 km
Section 3	: :	0:30:00	: :		SS Distance	19.44 km
TC 7	Marble Hill Road				Time Allowed	0:30:00 mins
TC 8	Fox Creek Road				Average Speed	53.48 km/h
SS 7 - Cherryville Plus 2						

Distance		Direction	Information	Distance To Go
Total	Part			
16.09	0.35		Start VC S 34° 50.969 E 138° 47.595	11.28
16.29	0.20		End VC S 34° 50.930 E 138° 47.724	11.08
16.54	0.25		SO FMR 	10.83
17.53	0.99		! Care RGR and Tightens S 34° 50.603 E 138° 47.744	9.84
18.53	1.00		RGHR	8.84
19.21	0.68		RGHR and tightens	8.16

Day 1	Your Start Time	Time Allowed	Due Time @ TC		Total Distance	26.74 km
Section 3	: : :	0:30:00	: : :		SS Distance	19.44 km
TC 7	Marble Hill Road				Time Allowed	0:30:00 mins
TC 8	Fox Creek Road				Average Speed	53.48 km/h
SS 7 - Cherryville Plus 2						







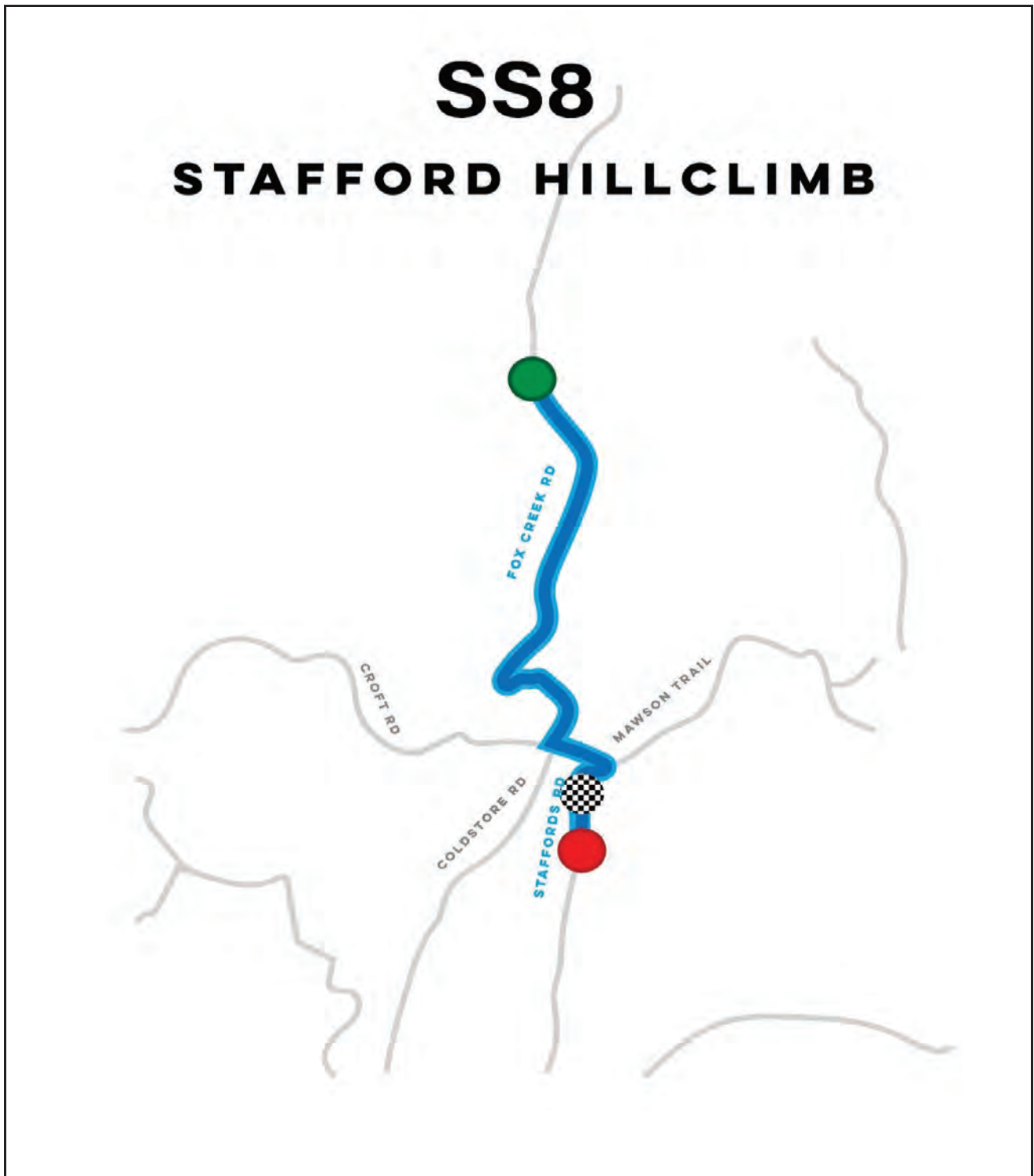

Distance		Direction	Information	Distance To Go
Total	Part			
19.44	0.23		<p>Flying Finish</p> <p>S 34° 50.370 E 138° 48.558</p>	7.93
19.62	0.18		<p>Stop Point then 20m SO</p> <p>S 34° 50.464 E 138° 48.595</p>	7.75
21.00	1.38		<p>SO</p>	6.37
22.30	1.30		<p>TR</p>	5.07
24.12	1.82		<p>TR</p>	3.25
26.74	2.62		<p>TC In then 30m Start</p>	0.63

Day 1	Your Start Time	Time Allowed	Due Time @ TC		Total Distance	23.37 km
Section 3	: : :	0:30:00	: : :		SS Distance	2.53 km
TC 8	Fox Creek Road				Time Allowed	0:30:00 mins
TC 8A	Bridgewater Oval				Average Speed	46.74 km/h
SS 8 - Stafford Hillclimb						

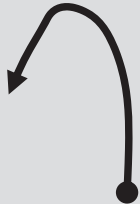
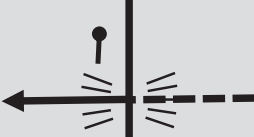

Distance		Direction	Information	Distance To Go
Total	Part			



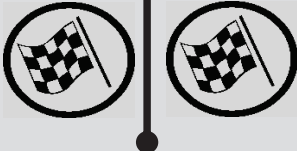



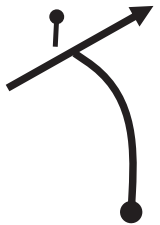

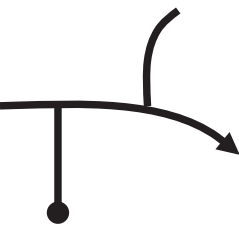
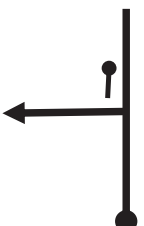
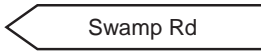
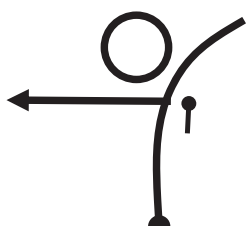
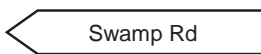
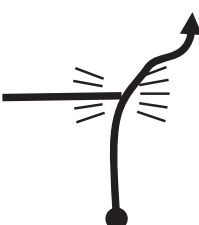

Day 1	Your Start Time	Time Allowed	Due Time @ TC		Total Distance	23.37 km
Section 3	: : :	0:30:00	: : :		SS Distance	2.53 km
TC 8	Fox Creek Road				Time Allowed	0:30:00 mins
TC 8A	Bridgewater Oval				Average Speed	46.74 km/h
SS 8 - Stafford Hillclimb						

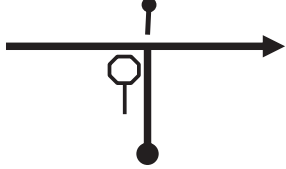

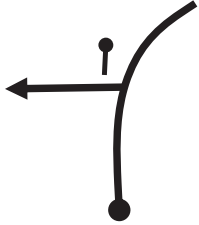
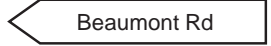
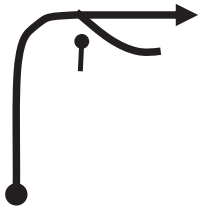
Distance		Direction	Information	Distance To Go
Total	Part			
0.00	0.00	 1 2.53	   Start S 34° 52.623 E 138° 50.317	23.37
0.68	0.68	 2 1.85	Crest	22.69
1.46	0.78	 3 1.07	Hairpin Left	21.91
1.99	0.53	 4 0.54	TL on Crest 	21.38
2.21	0.22	 5 0.32	TR 	21.16
2.53	0.32	 6 0.00	Flying Finish S 34° 53.648 E 138° 50.429	20.84

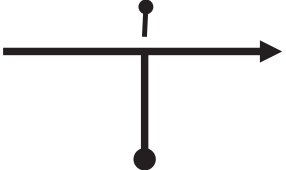
Day 1	Your Start Time	Time Allowed	Due Time @ TC		Total Distance	23.37 km
Section 3	: : :	0:30:00	: : :		SS Distance	2.53 km
TC 8	Fox Creek Road				Time Allowed	0:30:00 mins
TC 8A	Bridgewater Oval				Average Speed	46.74 km/h
SS 8 - Stafford Hillclimb						

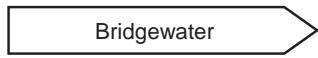
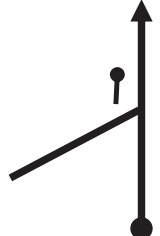
Distance		Direction	Information	Distance To Go
Total	Part			
2.83	0.30	 <p>7</p>	<p>Stop Point</p> <p>S 34° 53.821 E 138° 50.405</p>	20.54
3.84	1.01	 <p>8</p>	<p>TR @ TJ</p> 	19.53
4.81	0.97	 <p>9</p>	<p>TR @ TJ then 30m KR</p>	18.56
6.19	1.38	 <p>10</p>	<p>TL</p> 	17.18
8.90	2.71	 <p>11</p>	<p>TL (Fred's Tank)</p> 	14.47
11.37	2.47	 <p>12</p>	<p>RGR on Crest</p>	12.00



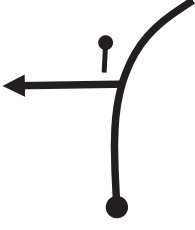

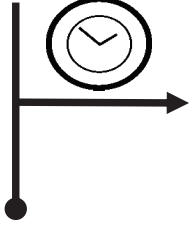
Day 1	Your Start Time	Time Allowed	Due Time @ TC		Total Distance	23.37 km
Section 3	: : :	0:30:00	: : :		SS Distance	2.53 km
TC 8	Fox Creek Road				Time Allowed	0:30:00 mins
TC 8A	Bridgewater Oval				Average Speed	46.74 km/h
SS 8 - Stafford Hillclimb						

Distance		Direction	Information	Distance To Go
Total	Part			
14.65	3.28	 13	STOP then TR @ TJ 	8.72
16.16	1.51	 14	TL 	7.21
16.60	0.44	 15	RGR then 20m SO 	6.77
19.11	2.51	 16	TR @ TJ 	4.26
20.38	1.27	 17	SO @ Roundabout 	2.99
22.92	2.54	 16	SO 	0.45

Day 1	Your Start Time	Time Allowed	Due Time @ TC			
Section 3	: : :	0:30:00	: : :		Total Distance	23.37 km
TC 8	Fox Creek Road				SS Distance	2.53 km
TC 8A	Bridgewater Oval				Time Allowed	0:30:00 mins
SS 8 - Stafford Hillclimb					Average Speed	46.74 km/h
Distance		Direction	Information	Distance To Go		
Total	Part					
23.32	0.40	 18	<p>TL</p> 	0.05		
23.37	0.05		 19	<p>TR then TC In</p>	0.00	

Day 1	Your Start Time	Time Allowed	Due Time @ TC		Total Distance	17.49 km
Section 4	: :	0:18:00	: :			
TC 8B	Bridgewater Oval					
TC 9	Hunters Road				Time Allowed	0:18:00 mins
LIAISON ONLY					Average Speed	58.30 km/h

Distance		Direction	Information	Distance To Go
Total	Part			

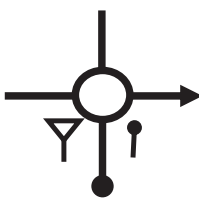
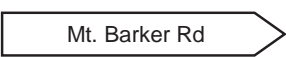
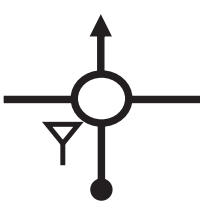
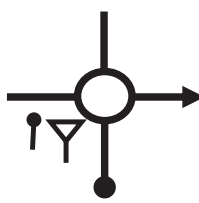
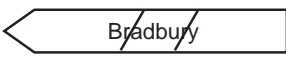
0.00	0.00	 <p>1</p>	 TC Out TL thru Gate	17.49
0.04	0.04	 <p>2</p>	TL @ TJ	17.45
0.15	0.11	 <p>3</p>	SO 	17.34
2.34	2.19	 <p>4</p>	GIVE WAY then TR @ Roundabout 	15.15
4.50	2.16	 <p>5</p>	GIVE WAY then SO @ Roundabout	12.99
4.86	0.36	 <p>6</p>	GIVE WAY then TR @ Roundabout 	12.63

Day 1	Your Start Time	Time Allowed	Due Time @ TC			
Section 4	: : :	0:18:00	: : :		Total Distance	17.49 km
TC 8B	Bridgewater Oval					
TC 9	Hunters Road				Time Allowed	0:18:00 mins
LIAISON ONLY					Average Speed	58.30 km/h







Distance		Direction	Information	Distance To Go
Total	Part			
5.95	1.09	<p>7</p>	<p>GIVE WAY then TL @ TJ</p> <p>← Stirling Golf Club</p> <p>then 50m TR</p> <p>→ Old Mt. Barker Rd</p>	11.54
6.61	0.66	<p>8</p>	<p>TL</p> <p>← Old Carey Gully Rd</p>	10.88
7.85	1.24	<p>9</p>	<p>TL</p> <p>← Spring Gully Rd</p>	9.64
9.25	1.40	<p>10</p>	<p>TR @ TJ</p> <p>FMR</p>	8.24
12.70	3.45	<p>11</p>	<p>GIVE WAY then TR @ TJ</p> <p>→ Greenhill Rd</p>	4.79
13.95	1.25	<p>12</p>	<p>TL</p> <p>← Basket Range Rd</p>	3.54

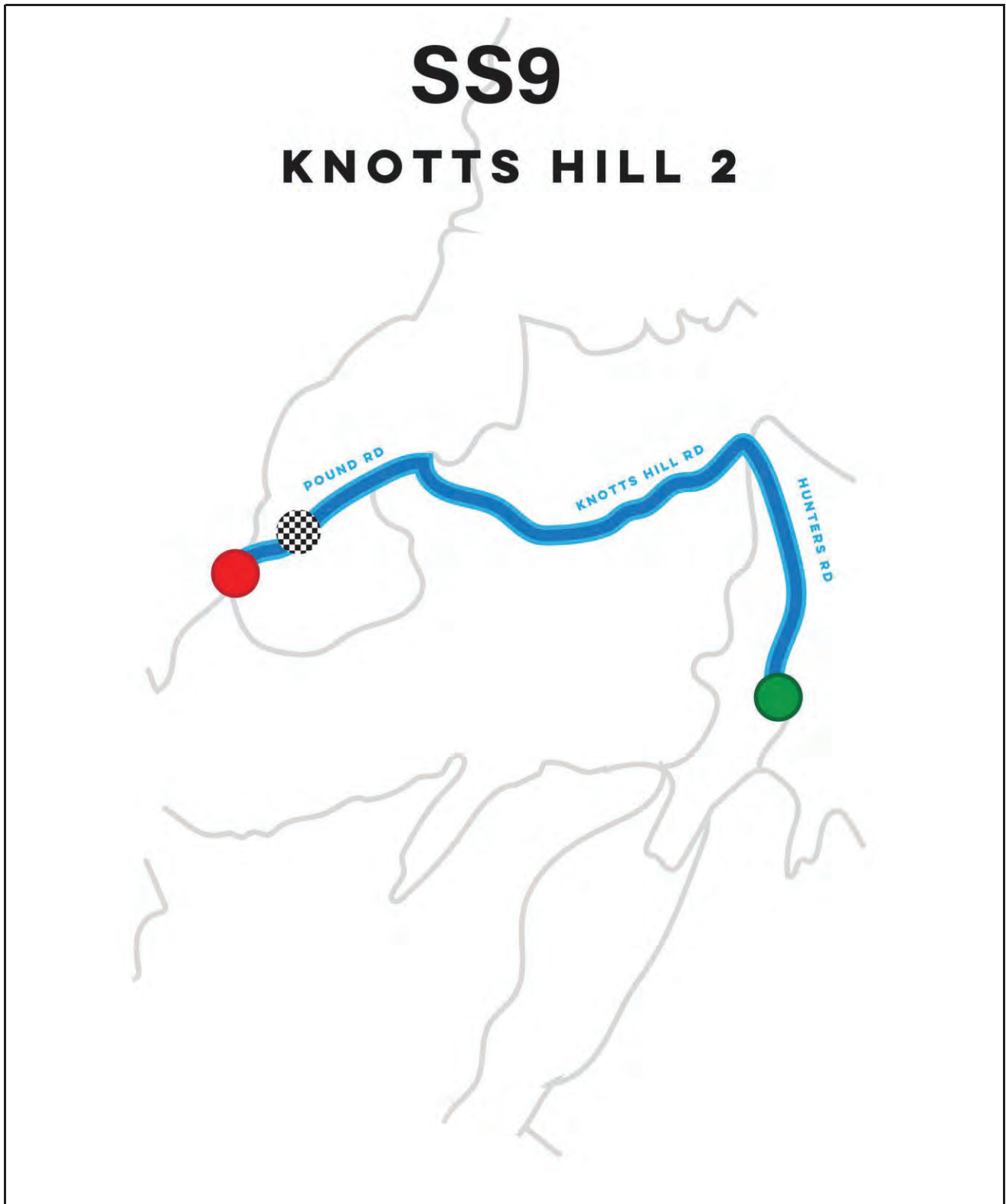

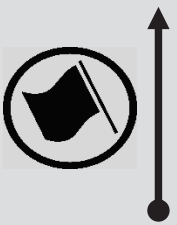
Day 1 Section 4	Your Start Time : : :	Time Allowed 0:18:00	Due Time @ TC : : :		Total Distance	17.49 km
TC 8B TC 9	Bridgewater Oval Hunters Road				Time Allowed	0:18:00 mins
LIAISON ONLY					Average Speed	58.30 km/h
Distance		Direction	Information	Distance To Go		
Total	Part					
16.76	2.81	 13	TR @ TJ 	0.73		
17.18	0.42	 14	TL 	0.31		
17.49	0.31	 15	TC In then 30m Start	0.00		

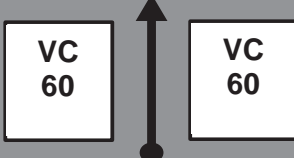
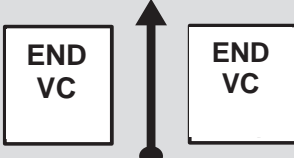
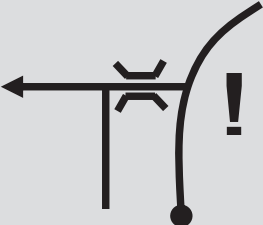

Day 1	Your Start Time	Time Allowed	Due Time @ TC		Total Distance	16.08 km
Section 4	: :	0:16:00	: :		SS Distance	3.46 km
TC 9	Hunters Road				Time Allowed	0:16:00
TC 10	Old Norton Summit Road				Average Speed	60.30 km/h
SS 9 - Knotts Hill 2						

Distance		Direction	Information	Distance To Go
Total	Part			

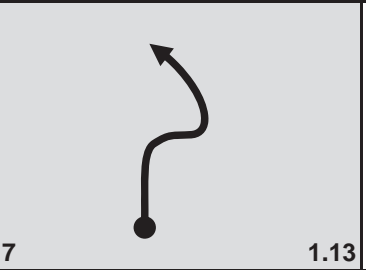
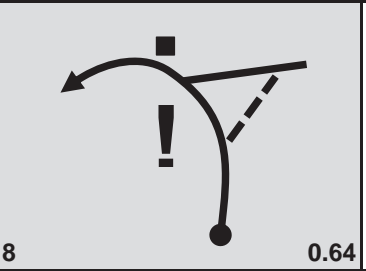
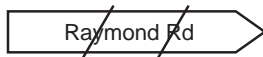
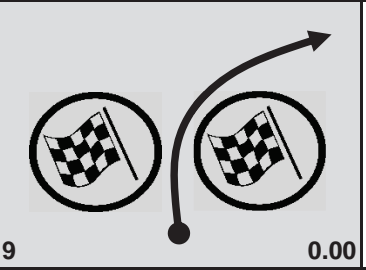
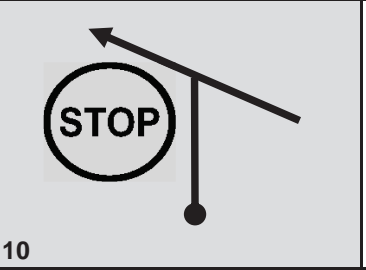
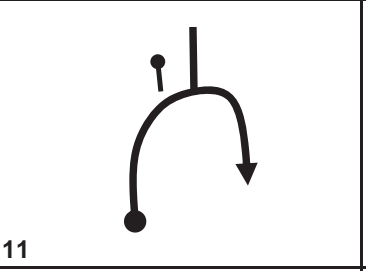

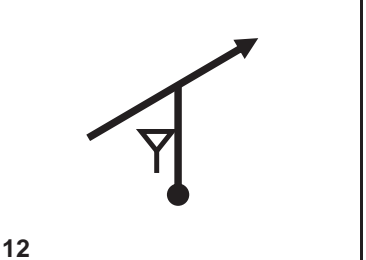
Day 1	Your Start Time	Time Allowed	Due Time @ TC		Total Distance	16.08 km
Section 4	: :	0:16:00	: :		SS Distance	3.46 km
TC 9	Hunters Road				Time Allowed	0:16:00
TC 10	Old Norton Summit Road				Average Speed	60.30 km/h
SS 9 - Knotts Hill 2						
Distance		Direction	Information	Distance To Go		
Total	Part					
0.00	0.00	 1 3.46	  Start S 34° 56.233 E 138° 46.232	16.08		
0.37	0.37	 2 3.09	! Care RGL on Crest S 34° 56.047 E 138° 46.244	15.71		
0.76	0.39	 3 2.70	Start VC S 34° 55.848 E 138° 46.227	15.32		
0.96	0.20	 4 2.50	End VC S 34° 55.741 E 138° 46.173	15.12		
1.14	0.18	 5 2.32	! Care TL onto Bridge then SO S 34° 55.664 E 138° 46.134	14.94		
1.98	0.84	 6 1.48	RGL then 30m RGR	14.10		

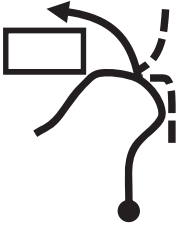
Day 1	Your Start Time	Time Allowed	Due Time @ TC		Total Distance	16.08 km
Section 4	: :	0:16:00	: :		SS Distance	3.46 km
TC 9	Hunters Road				Time Allowed	0:16:00
TC 10	Old Norton Summit Road				Average Speed	60.30 km/h
SS 9 - Knotts Hill 2						
Distance		Direction	Information	Distance To Go		
Total	Part					
2.33	0.35		RGR then 30m RGL	13.75		
2.82	0.49		! Care RGL then Tightens Keep in on Exit  S 34° 55.709 E 138° 45.245	13.26		
3.46	0.64		Flying Finish S 34° 55.852 E 138° 44.890	12.62		
3.75	0.29		Stop Point then 20m TL @ TJ S 34° 55.941 E 138° 44.705	12.33		
4.40	0.65		KHR 	11.68		
5.08	0.68		GIVE WAY then TR @ TJ	11.00		

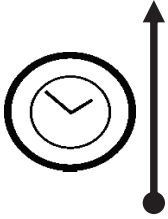
Day 1	Your Start Time	Time Allowed	Due Time @ TC			
Section 4	: : :	0:16:00	: : :		Total Distance	16.08 km
TC 9	Hunters Road				SS Distance	3.46 km
TC 10	Old Norton Summit Road				Time Allowed	0:16:00
SS 9 - Knotts Hill 2					Average Speed	60.30 km/h
Distance		Direction	Information	Distance To Go		
Total	Part					
6.75	1.67	 13	<p>TR Onto Norton Summit Rd</p>	9.33		
14.09	7.34	 14	<p>GIVE WAY then TL @ TJ</p>	1.99		
16.08	1.99	 15	<p>TC In then 30m Start</p>	0.00		





Day 1	Your Start Time	Time Allowed	Due Time @ TC			
Section 4	: : :	0:10:00	: : :		Total Distance	7.92 km
TC 10	Old Norton Summit Road				SS Distance	3.07 km
TC 10A	Woods Hill Road				Time Allowed	0:10:00
SS 10 - Old Norton Summit 2					Average Speed	47.52 km/h

Distance		Direction	Information	Distance To Go
Total	Part			

SS10

OLD NORTON SUMMIT 2

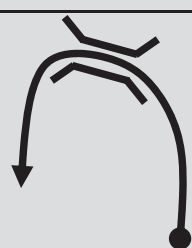
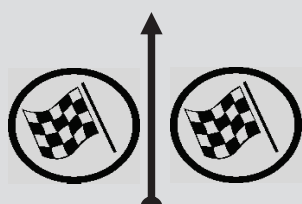
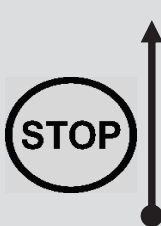

Day 1		Your Start Time	Time Allowed	Due Time @ TC			
Section 4		: :	0:10:00	: :	Total Distance	7.92 km	
TC 10		Old Norton Summit Road			SS Distance	3.07 km	
TC 10A		Woods Hill Road			Time Allowed	0:10:00	
SS 10 - Old Norton Summit 2					Average Speed	47.52 km/h	
Distance		Direction			Information		
Total	Part				Distance To Go		
0.00	0.00	 1 3.07			  Start S 34° 55.291 E 138° 41.907		7.92
0.04	0.04	 2 3.03			RGL Do Not Cut		7.88
1.50	1.46	 3 1.57			RGL Do Not Cut		6.42
2.44	0.94	 4 0.63			Haripin Left over Bridge		5.48
3.07	0.63	 5 0.00			Flying Finish S 34° 55.484 E 138° 43.334		4.85
3.37	0.30	 6			Stop Point S 34° 55.385 E 138° 43.456		4.55







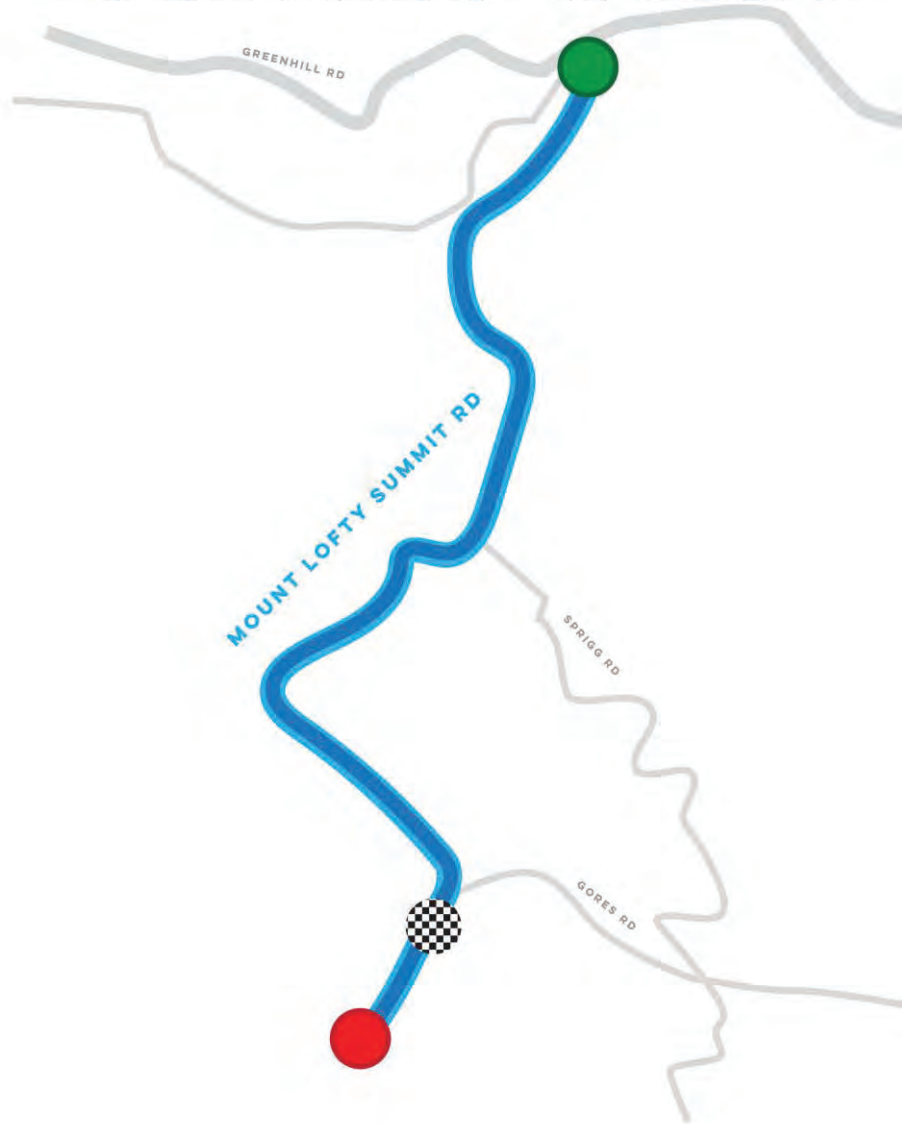

Day 1 Section 5	Your Start Time : : :	Time Allowed 0:05:00	Due Time @ TC : : :		Total Distance	0.45 km
TC 10B	Woods Hill Road					
TC 11	Mount Lofty Summit Road				Time Allowed	0:05:00 mins
LIAISON ONLY					Average Speed	5.40 km/h
Distance		Direction	Information	Distance To Go		
Total	Part					
0.00	0.00		 TC Out TR 	0.45		
0.32	0.32		TL 	0.13		
0.45	0.13		TC In then 30m Start	0.00		

Day 1	Your Start Time	Time Allowed	Due Time @ TC		Total Distance	21.25 km
Section 5	: :	0:30:00	: :		SS Distance	1.64 km
TC 11	Mount Lofty Summit Road				Time Allowed	0:30:00
TC 11A	Adelaide Showgrounds				Average Speed	42.50 km/h
SS 11 - Summit Road						

Distance		Direction	Information	Distance To Go
Total	Part			

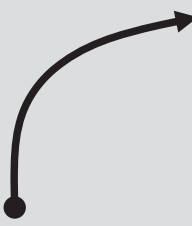
SS11 SUMMIT ROAD

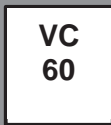

Day 1	Your Start Time	Time Allowed	Due Time @ TC		Total Distance	21.25 km
Section 5	: : :	0:30:00	: : :		SS Distance	1.64 km
TC 11	Mount Lofty Summit Road				Time Allowed	0:30:00
TC 11A	Adelaide Showgrounds				Average Speed	42.50 km/h
SS 11 - Summit Road						
Distance		Direction	Information	Distance To Go		
Total	Part					
0.00	0.00	 1 1.64	  Start S 34° 57.517 E 138° 42.933	21.25		
0.11	0.11	 2 1.53	Crest then RGR then RGL	21.14		
0.46	0.35	 3 1.18	RGR	20.79		
0.72	0.26	 4 0.92	RGR and Tightens then RGL and ! Care Tightens S 34° 57.851 E 138° 42.851	20.53		
1.09	0.37	 5 0.55	 !! Caution RGL and Tightens S 34° 57.953 E 138° 42.688	20.16		
1.38	0.29	  6 0.26	Start VC S 34° 58.066 E 138° 42.738	19.87		

Day 1	Your Start Time	Time Allowed	Due Time @ TC			
Section 5	: : :	0:30:00	: : :		Total Distance	21.25 km
TC 11	Mount Lofty Summit Road				SS Distance	1.64 km
TC 11A	Adelaide Showgrounds				Time Allowed	0:30:00
SS 11 - Summit Road					Average Speed	42.50 km/h
Distance		Direction	Information	Distance To Go		
Total	Part					
1.58	0.20	<p>7 0.06</p>	<p>RGR End VC</p> <p>S 34° 58.152 E 138° 42.832</p>	19.67		
1.64	0.06	<p>8 0.00</p>	<p>Flying Finish on Crest</p> <p>S 34° 58.171 E 138° 42.814</p>	19.61		
1.86	0.22	<p>9</p>	<p>Stop Point</p> <p>S 34° 58.268 E 138° 42.736</p>	19.39		
2.91	1.05	<p>10</p>	<p>RGR FMR</p>	18.34		
5.54	2.63	<p>11</p>	<p>Roundabout SO</p>	15.71		
5.74	0.20	<p>12</p>	<p>TR @ Roundabout</p>	15.51		

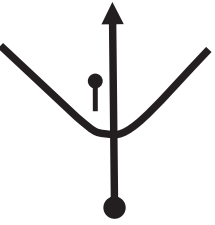
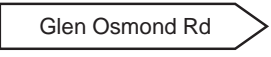
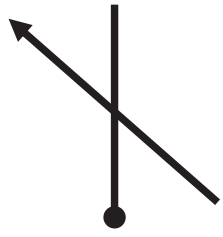
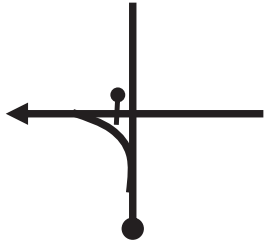
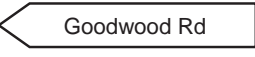
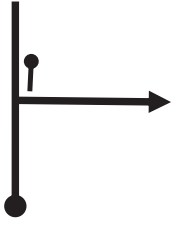
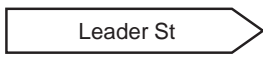
Day 1	Your Start Time	Time Allowed	Due Time @ TC			
Section 5	: : :	0:30:00	: : :		Total Distance	21.25 km
TC 11	Mount Lofty Summit Road				SS Distance	1.64 km
TC 11A	Adelaide Showgrounds				Time Allowed	0:30:00
SS 11 - Summit Road					Average Speed	42.50 km/h
Distance		Direction	Information	Distance To Go		
Total	Part					
6.36	0.62		! Care Merge onto Freeway	14.89		
13						
Continue on the South Eastern Freeway towards Adelaide CBD.						
14.07	7.71		SO @ XR 	7.18		
14						
Continue on Glen Osmond Road, crossing over Bevington Rd and Fullarton Rd.						
17.79	3.72		TL @ XR (Greenhill Road)	3.46		
15						
Continue on Greenhill Road, crossing over Unley Road, and King William Road.						
20.18	2.39		TL @ XR 	1.07		
16						
20.90	0.72		TR Hard to see 	0.35		
17						

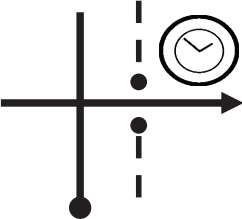
Day 1	Your Start Time	Time Allowed	Due Time @ TC			
Section 5	: : :	0:30:00	: : :		Total Distance	21.25 km
TC 11	Mount Lofty Summit Road				SS Distance	1.64 km
TC 11A	Adelaide Showgrounds				Time Allowed	0:30:00
SS 11 - Summit Road					Average Speed	42.50 km/h
Distance		Direction		Information		Distance To Go
Total	Part					
21.25	0.35			<p>TR then TC IN</p> <p>Follow the direction of Officials</p>		0.00



Government
of South Australia

ADELAIDE RALLY
• 2024 •

**2024 SHANNONS
ADELAIDE RALLY**
NOVEMBER 8-10



DAY 2

ADELAIDE RALLY • 2024 •

**Day 2 - Saturday
9th Nov. 2024**

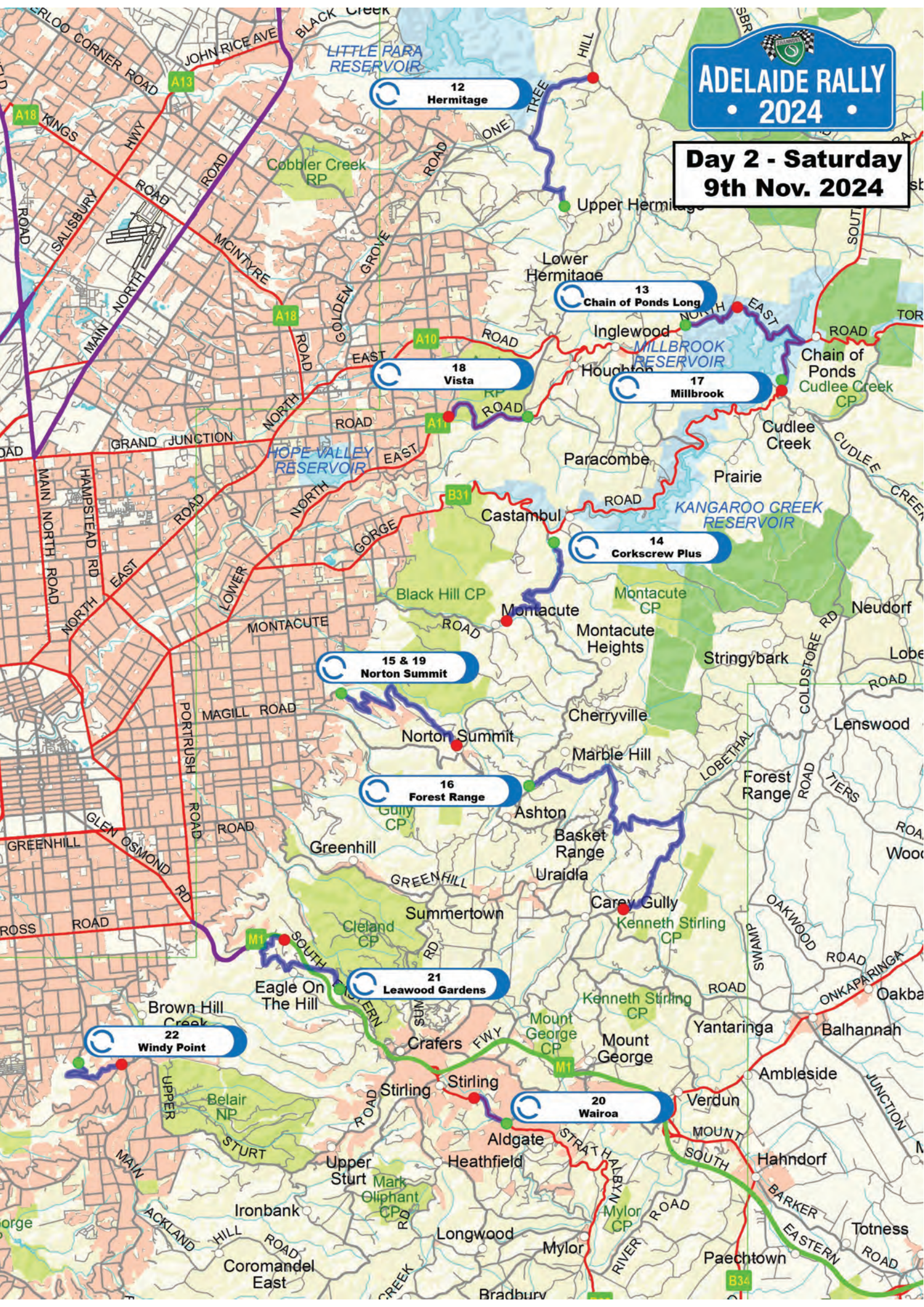

2024 Shannons Adelaide Rally

Saturday, 9th November, 2024

Section:	TC/SS	Label	E	L	R	RV	Comp KM	Liaison KM	Section Total	Target Time	First Car	
		11B	Depart Parc Ferme									8:15
1	12							29.29	29.29	1:00		
	SS 12	Hermitage					4.99				9:15	
	13							14.51	19.50	0:23		
	SS 13	Chain of Ponds Long				RV	5.91				9:38	
	14							12.09	18.00	0:22		
	SS 14	Corkscrew Plus					3.79				10:00	
2	14A	Regroup E - Foxfield In	E					4.91	8.70	0:10	10:10	
	14B	Regroup E - Foxfield Out								0:30	10:40	
	15							7.39	7.39	0:10		
	SS 15	Norton Summit 1				R	5.49				10:50	
3	15A	Regroup F - Bridgewater In	E	L				21.24	26.73	0:27	11:17	
	15B	Regroup F - Bridgewater Out								1:00	12:17	
	16							17.21	17.21	0:18		
	SS 16	Knotts Range					10.36				12:35	
	17							27.10	37.46	0:42		
	SS 17	Millbrook					3.99				13:17	
4	18							8.09	12.08	0:15		
	SS 18	Vista 2					2.60				13:32	
	18A	Regroup G - Foxfield In	E					11.59	14.19	0:16	13:48	
	18B	Regroup G - Foxfield Out								0:30	14:18	
5	19							7.39	7.39	0:10		
	SS 19	Norton Summit 2					5.49				14:28	
	19A	Regroup H - Aldgate In						16.39	21.88	0:26	14:54	
6	19B	Regroup H - Aldgate Out								0:01	14:55	
	20							0.03	0.03	0:01		
	SS 20	Wairoa					0.83				14:56	
	21							5.57	6.40	0:10		
	SS 21	Leawood Gardens					3.62				15:06	
	22							10.95	14.57	0:13		
6	SS 22	Windy Point					2.03				15:19	
	22A	Street Party - Gouger In	E					12.94	14.97	0:40	15:59	
	22B	Street Party - Gouger Out									20:00	
	22C	Arrive Parc Ferme	E								N/A	
DAILY TOTAL							49.10	206.66	255.76			





'E' indicates entry to regroup or parc ferme without penalty.

'L' indicates designated lunch stop.

'R' indicates this stage is repeated on this day.

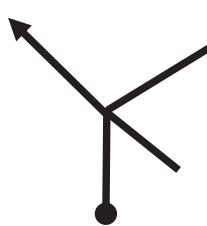
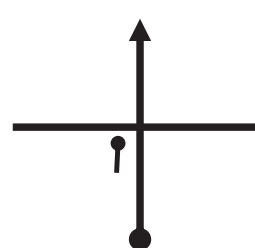
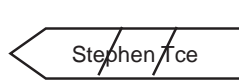
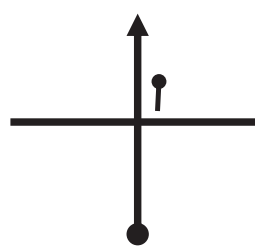
'RV' indicates this stage is reversed on this day.

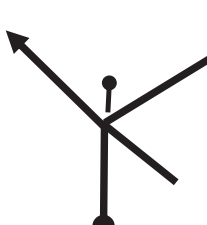
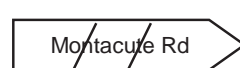
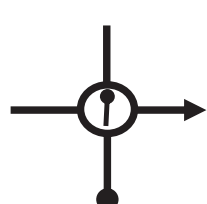
Day 2 Section 1	Your Start Time : : :	Time Allowed 1:00:00	Due Time @ TC : : :		Total Distance	29.29 km
TC 11B TC 12	Adelaide Showgrounds Range Road North				Time Allowed	1:00:00
LIASON ONLY					Average Speed	29.29 km/h
Distance		Direction	Information	Distance To Go		
Total	Part					
0.00	0.00	<p>1</p>	<p>TC Out then 30m TL</p>	29.29		
0.37	0.37	<p>2</p>	TL @ TJ	28.92		
1.10	0.73	<p>3</p>	<p>SO @ XR</p>	28.19		
<p>FMR along Goodwood Road. Cross over South Terrace onto West Terrace. Continue over Sturt Street, Grote Street, and Currie Street. Move to the right lane, and turn right onto North Terrace.</p>						
3.27	2.17	<p>4</p>	<p>TR @ TJ</p>	26.02		
5.85	2.58	<p>5</p>	<p>SO @ XR</p>	23.44		







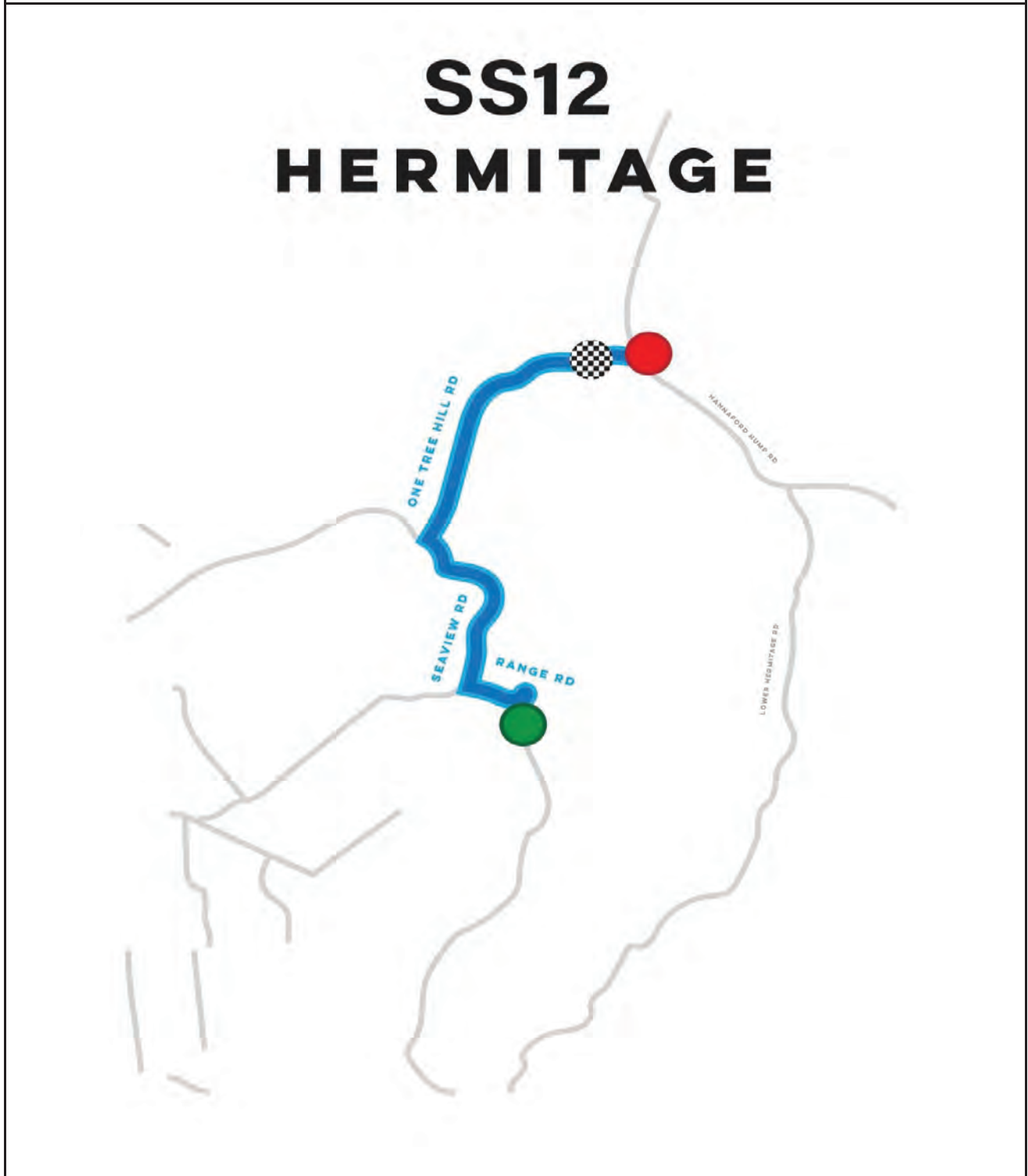

Day 2 Section 1	Your Start Time : : :	Time Allowed 1:00:00	Due Time @ TC : : :		Total Distance	29.29 km
TC 11B TC 12	Adelaide Showgrounds Range Road North				Time Allowed	1:00:00
LIASON ONLY					Average Speed	29.29 km/h
Distance		Direction	Information	Distance To Go		
Total	Part					
6.69	0.84	 6	KL (onto Payneham Road)	22.60		
7.52	0.83	 7	SO @ XR 	21.77		
9.26	1.74	 8	SO @ XR 	20.03		
FMR to KL on Lower North East Road. Move to Left Lane.						
11.03	1.77	 9	KL FMR 	18.26		
19.65	8.62	 10	TR @ Roundabout 	9.64		

Day 2	Your Start Time	Time Allowed	Due Time @ TC		Total Distance	29.29 km
Section 1	: : :	1:00:00	: : :			
TC 11B	Adelaide Showgrounds					
TC 12	Range Road North				Time Allowed	1:00:00
LIASON ONLY					Average Speed	29.29 km/h
Distance		Direction	Information	Distance To Go		
Total	Part					
19.93	0.28	<p>11</p>	<p>TL</p>	9.36		
22.18	2.25	<p>12</p>	<p>TR @ TJ</p>	7.11		
24.74	2.56	<p>13</p>	<p>TL on Crest then SO</p> <p>! Care On-coming Rally Traffic</p>	4.55		
28.44	3.70	<p>14</p>	<p>KL</p>	0.85		
29.29	0.85	<p>15</p>	<p>TC In then 30m Start</p>	0.00		



Day 2	Your Start Time	Time Allowed	Due Time @ TC		Total Distance	19.50 km
Section 1	: : :	0:23:00	: : :		SS Distance	4.99 km
TC 12	Range Road North				Time Allowed	0:23:00
TC 13	North East Road				Average Speed	50.87 km/h
SS 12 - Hermitage						

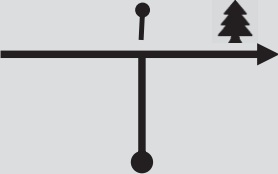





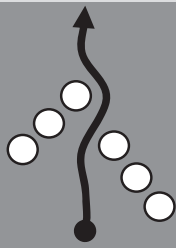
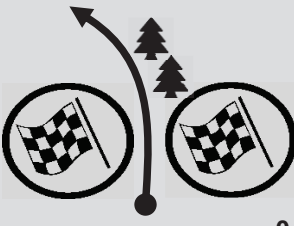
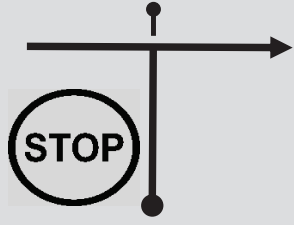

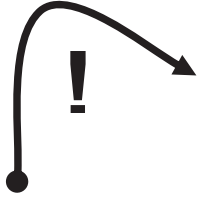
Distance		Direction	Information	Distance To Go
Total	Part			

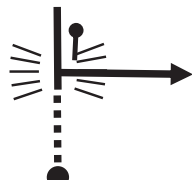

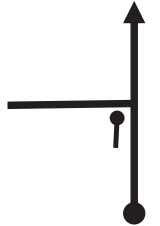
Day 2	Your Start Time	Time Allowed	Due Time @ TC			
Section 1	: : :	0:23:00	: : :		Total Distance	19.50 km
TC 12	Range Road North				SS Distance	4.99 km
TC 13	North East Road				Time Allowed	0:23:00
SS 12 - Hermitage					Average Speed	50.87 km/h
Distance		Direction	Information	Distance To Go		
Total	Part					
0.00	0.00	 1  4.99	  Start S 34° 47.227 E 138° 45.532	19.50		
0.16	0.16	 2 4.83	RGR then 80m Hairpin Left	19.34		
0.60	0.44	 3 4.39	RGL on Crest	18.90		
0.82	0.22	 4 4.17	TR @ TJ Narrow Exit 	18.68		
0.97	0.15	 5 4.02	RGL ! Care Do Not Cut S 34° 46.986 E 138° 45.282	18.53		

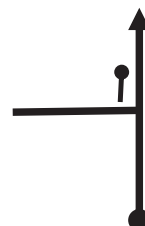
Day 2	Your Start Time	Time Allowed	Due Time @ TC			
Section 1	: : :	0:23:00	: : :		Total Distance	19.50 km
TC 12	Range Road North				SS Distance	4.99 km
TC 13	North East Road				Time Allowed	0:23:00
SS 12 - Hermitage					Average Speed	50.87 km/h
Distance		Direction	Information	Distance To Go		
Total	Part					
1.18	0.21		Start VC S 34° 46.878 E 138° 45.278	18.32		
1.21	0.03		Crest	18.29		
1.38	0.17		End VC S 34° 46.761 E 138° 45.309	18.12		
1.68	0.30		RGL ! Care Do Not Cut S 34° 46.628 E 138° 45.375	17.82		
2.15	0.47		! Care RGR then Tightens then RGL S 34° 46.485 E 138° 45.133	17.35		
2.55	0.40		!! Caution TVHR Do Not Cut One Tree Hill Rd S 34° 46.331 E 138° 45.003	16.95		

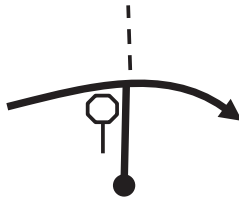
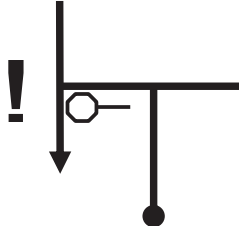
Day 2	Your Start Time	Time Allowed	Due Time @ TC			
Section 1	: : :	0:23:00	: : :		Total Distance	19.50 km
TC 12	Range Road North				SS Distance	4.99 km
TC 13	North East Road				Time Allowed	0:23:00
SS 12 - Hermitage					Average Speed	50.87 km/h
Distance		Direction	Information	Distance To Go		
Total	Part					
3.55	1.00	 12 1.44	! Care SO over Bridge S 34° 45.860 E 138° 45.224	15.95		
3.62	0.07	 13 1.37	Slow Point S 34° 45.807 E 138° 45.251	15.88		
4.99	1.37	 14 0.00	Flying Finish S 34° 45.474 E 138° 45.927	14.51		
5.36	0.37	 15	Stop Point then TR @ TJ  S 34° 45.447 E 138° 46.158	14.14		
5.58	0.22	 16	Start Gravel	13.92		
5.93	0.35	 17	! Care RGHR	13.57		

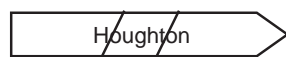
Day 2	Your Start Time	Time Allowed	Due Time @ TC			
Section 1	: : :	0:23:00	: : :		Total Distance	19.50 km
TC 12	Range Road North				SS Distance	4.99 km
TC 13	North East Road				Time Allowed	0:23:00
SS 12 - Hermitage					Average Speed	50.87 km/h
Distance		Direction	Information	Distance To Go		
Total	Part					
7.27	1.34	 18	TR on Crest Start Bitumen 	12.23		
8.26	0.99	 19	SO 	11.24		
9.65	1.39	 20	SO 	9.85		
14.50	4.85	 21	STOP then TR @ TJ	5.00		
14.74	0.24	 22	TL @ TJ then 40m STOP TL @ TJ ! Care Oncoming Rally Traffic	4.76		
16.20	1.46	 23	SO 	3.30		

Day 2	Your Start Time	Time Allowed	Due Time @ TC			
Section 1	: : :	0:23:00	: : :		Total Distance	19.50 km
TC 12	Range Road North				SS Distance	4.99 km
TC 13	North East Road				Time Allowed	0:23:00
SS 12 - Hermitage					Average Speed	50.87 km/h
Distance		Direction	Information	Distance To Go		
Total	Part					
17.74	1.54	<p>24</p>	<p>SO</p>	1.76		
19.40	1.66	<p>25</p>	<p>SO</p>	0.10		
19.50	0.10	<p>26</p>	<p>TC In then 30m Start</p>	0.00		





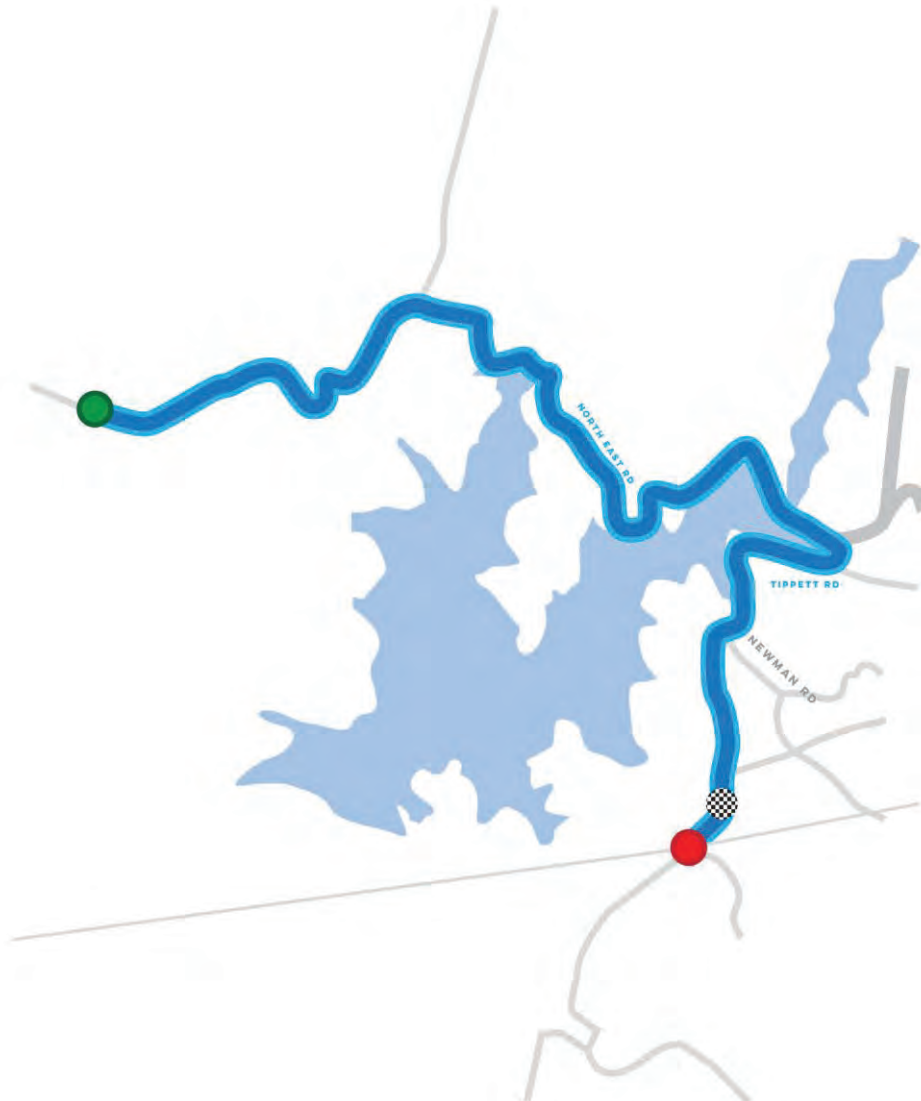

Day 2	Your Start Time	Time Allowed	Due Time @ TC			
Section 1	: : :	0:22:00	: : :		Total Distance	18.00 km
TC 13	North East Road				SS Distance	5.91 km
TC 14	Corkscrew Road				Time Allowed	0:22:00
SS 13 - Chain of Ponds Long					Average Speed	49.09 km/h

Distance		Direction	Information	Distance To Go
Total	Part			



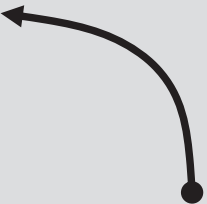
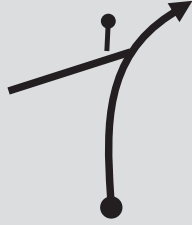

SS13

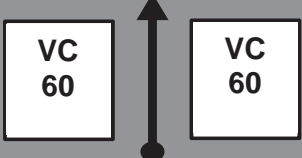
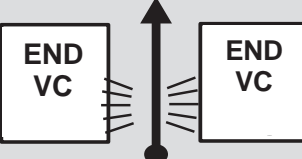
CHAIN OF PONDS LONG

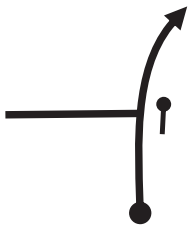

Day 2	Your Start Time	Time Allowed	Due Time @ TC			
Section 1	: : :	0:22:00	: : :		Total Distance	18.00 km
TC 13	North East Road				SS Distance	5.91 km
TC 14	Corkscrew Road				Time Allowed	0:22:00
SS 13 - Chain of Ponds Long					Average Speed	49.09 km/h
Distance		Direction	Information	Distance To Go		
Total	Part					
0.00	0.00	 1 5.91	   Start S 34° 49.121 E 138° 47.735	18.00		
0.60	0.60	 2 5.31	RGR then !! Caution RGL on Crest S 34° 49.043 E 138° 48.094	17.40		
0.95	0.35	 3 4.96	RGL Long	17.05		
1.74	0.79	 4 4.17	RGR 	16.26		
2.68	0.94	 5 3.23	Start VC S 34° 49.149 E 138° 49.023	15.32		
2.88	0.20	 6 3.03	End VC on Crest S 34° 49.241 E 138° 49.103	15.12		

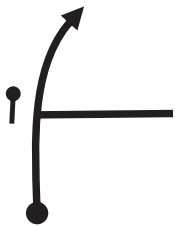
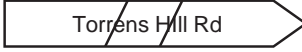
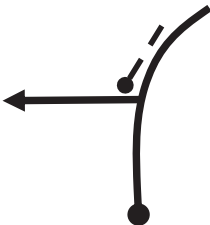
Day 2	Your Start Time	Time Allowed	Due Time @ TC			
Section 1	: : :	0:22:00	: : :		Total Distance	18.00 km
TC 13	North East Road				SS Distance	5.91 km
TC 14	Corkscrew Road				Time Allowed	0:22:00
SS 13 - Chain of Ponds Long					Average Speed	49.09 km/h
Distance		Direction	Information	Distance To Go		
Total	Part					
4.47	1.59		<p>TR</p>	13.53		
5.34	0.87		<p>Start VC</p> <p>S 34° 49.636 E 138° 49.415</p>	12.66		
5.54	0.20		<p>!! Caution RGL on Crest End VC</p> <p>S 34° 49.745 E 138° 49.432</p>	12.46		
5.91	0.37		<p>Flying Finish</p> <p>S 34° 49.948 E 138° 49.450</p>	12.09		
6.27	0.36		<p>Stop Point</p> <p>S 34° 50.079 E 138° 49.360</p>	11.73		
6.57	0.30		<p>TR @ TJ</p>	11.43		

Day 2	Your Start Time	Time Allowed	Due Time @ TC		Total Distance	18.00 km
Section 1	: : :	0:22:00	: : :		SS Distance	5.91 km
TC 13	North East Road				Time Allowed	0:22:00
TC 14	Corkscrew Road				Average Speed	49.09 km/h
SS 13 - Chain of Ponds Long						
Distance		Direction	Information	Distance To Go		
Total	Part					
7.94	1.37	 13	SO 	10.06		
11.03	3.09	 14	SO 	6.97		
17.43	6.40	 15	TL	0.57		
18.00	0.57	 16	TC In then 30m Start	0.00		









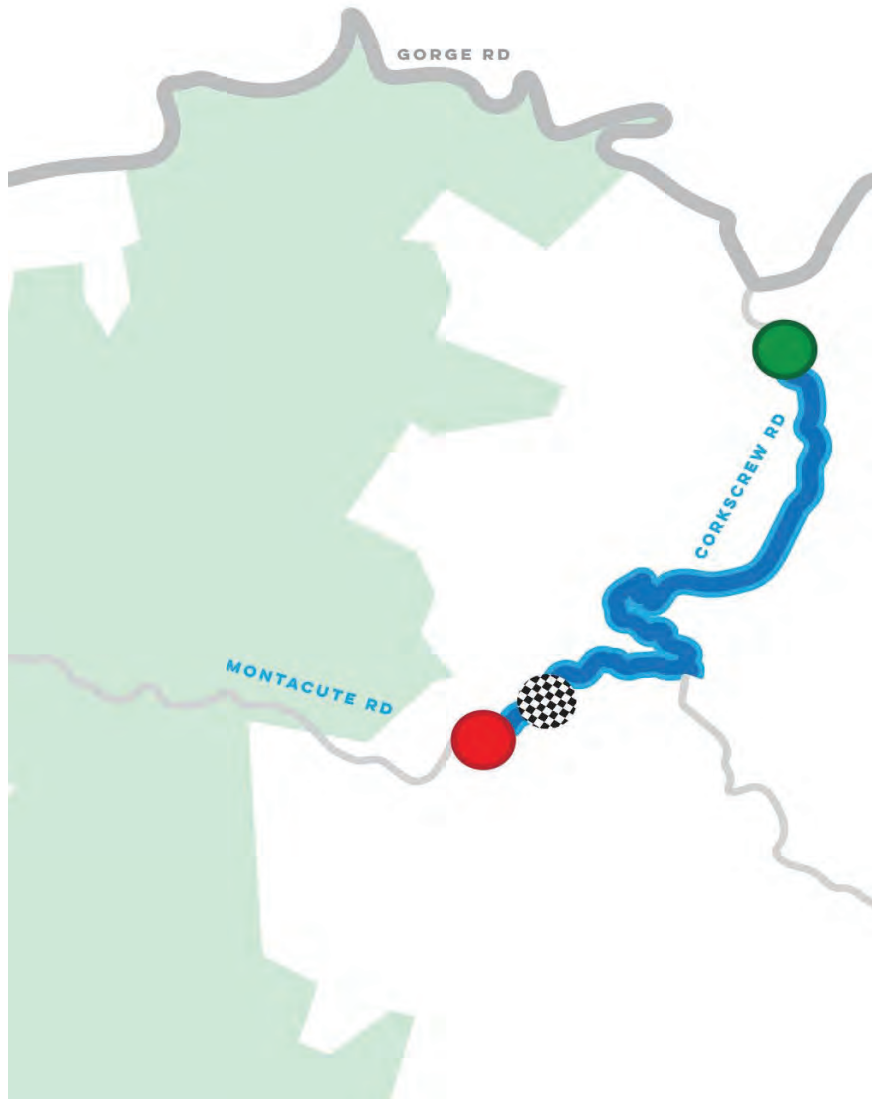

Day 2	Your Start Time	Time Allowed	Due Time @ TC			
Section 1	: : :	0:10:00	: : :		Total Distance	8.70 km
TC 14	Corkscrew Road				SS Distance	3.79 km
TC 14A	Foxfield Oval				Time Allowed	0:10:00
SS 14 - Corkscrew Plus					Average Speed	52.20 km/h

Distance		Direction	Information	Distance To Go
Total	Part			

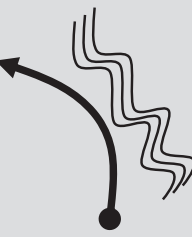

SS14





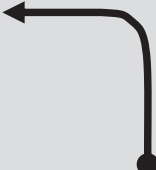
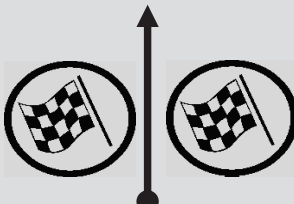
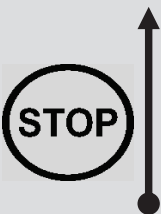
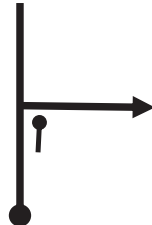

CORKSCREW PLUS

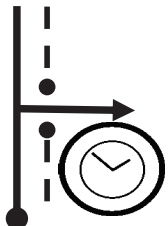

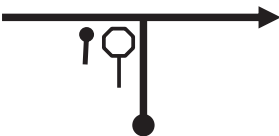
Day 2	Your Start Time	Time Allowed	Due Time @ TC			
Section 1	: : :	0:10:00	: : :		Total Distance	8.70 km
TC 14	Corkscrew Road				SS Distance	3.79 km
TC 14A	Foxfield Oval				Time Allowed	0:10:00
SS 14 - Corkscrew Plus					Average Speed	52.20 km/h
Distance		Direction	Information	Distance To Go		
Total	Part					
0.00	0.00	  1 3.79	  Start S 34° 52.358 E 138° 45.276	8.70		
0.07	0.07	  2 3.72	 RGHL Creek on Outside	8.63		
0.40	0.33	  3 3.39	RGL ! Care Rocks on Outside S 34° 52.582 E 138° 45.335	8.30		
0.59	0.19	  4 3.20	Narrow Bridge	8.11		

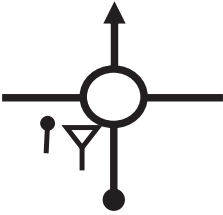
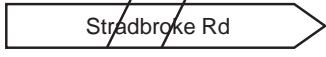
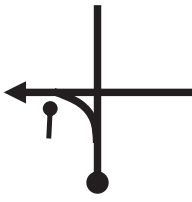
Day 2	Your Start Time	Time Allowed	Due Time @ TC			
Section 1	: : :	0:10:00	: : :		Total Distance	8.70 km
TC 14	Corkscrew Road				SS Distance	3.79 km
TC 14A	Foxfield Oval				Time Allowed	0:10:00
SS 14 - Corkscrew Plus					Average Speed	52.20 km/h
Distance		Direction	Information	Distance To Go		
Total	Part					
1.90	1.31		Hairpin Right	6.80		
1.99	0.09		Hairpin Left	6.71		
2.09	0.10		Hairpin Right	6.61		
2.20	0.11		Hairpin Left	6.50		
2.70	0.50		RGHR	6.00		
3.02	0.32		RGR then 20m TR @ TJ 	5.68		

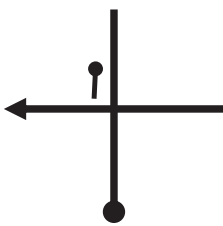
Day 2	Your Start Time	Time Allowed	Due Time @ TC			
Section 1	: : :	0:10:00	: : :		Total Distance	8.70 km
TC 14	Corkscrew Road				SS Distance	3.79 km
TC 14A	Foxfield Oval				Time Allowed	0:10:00
SS 14 - Corkscrew Plus					Average Speed	52.20 km/h
Distance		Direction	Information	Distance To Go		
Total	Part					
3.35	0.33	 11 0.44	RGR then RGL	5.35		
3.68	0.33	 12 0.11	RGL	5.02		
3.79	0.11	 13 0.00	Flying Finish S 34° 53.303 E 138° 44.521	4.91		
3.97	0.18	 14	Stop Point S 34° 53.399 E 138° 44.433	4.73		
8.22	4.25	 15	TR 	0.48		
8.70	0.48	 16	TR through Gate Then TC In	0.00		

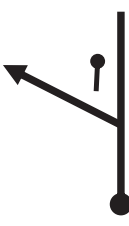
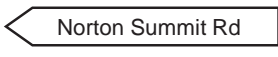
Day 2	Your Start Time	Time Allowed	Due Time @ TC		Total Distance	7.39 km
Section 2	: : :	0:10:00	: : :			
TC 14B	Foxfield Oval					
TC 15	Norton Summit Road				Time Allowed	0:10:00
LIASON ONLY					Average Speed	44.34 km/h
Distance		Direction	Information	Distance To Go		
Total	Part					
0.00	0.00	 1	0.00 Zero Trip Meter TC Out TL onto Main Road	7.39		
0.52	0.52	 2	STOP then TR @ TJ FMR 	6.87		
1.32	0.80	 3	GIVE WAY then SO @ Roundabout 	6.07		
2.99	1.67	 4	TL @ XR 	4.40		
5.69	2.70	 5	TL @ XR 	1.70		
6.14	0.45	 6	TL 	1.25		

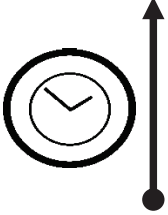
Day 2 Section 2	Your Start Time : : :	Time Allowed 0:10:00	Due Time @ TC : : :		Total Distance	7.39 km
TC 14B	Foxfield Oval					
TC 15	Norton Summit Road				Time Allowed	0:10:00
LIASON ONLY					Average Speed	44.34 km/h
Distance		Direction		Information		Distance To Go
Total	Part					
7.39	1.25			TC In then 30m Start		0.00
		7				







Day 2	Your Start Time	Time Allowed	Due Time @ TC			
Section 2	: : :	0:27:00	: : :		Total Distance	26.73 km
TC 15	Norton Summit Road				SS Distance	5.49 km
TC 15A	Bridgewater Oval				Time Allowed	0:27:00 mins
SS 15 - Norton Summit 1					Average Speed	59.40 km/h

Distance		Direction	Information	Distance To Go
Total	Part			

SS15

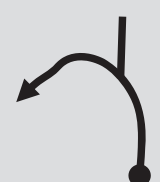
NORTON SUMMIT 1





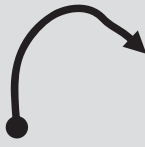
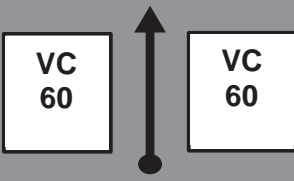
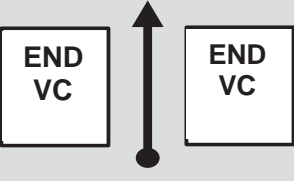
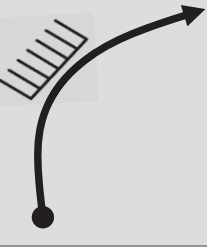
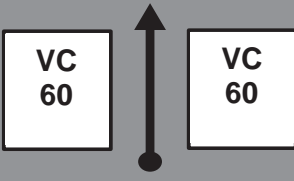

Day 2	Your Start Time	Time Allowed	Due Time @ TC			
Section 2	: : :	0:27:00	: : :		Total Distance	26.73 km
TC 15	Norton Summit Road				SS Distance	5.49 km
TC 15A	Bridgewater Oval				Time Allowed	0:27:00 mins
SS 15 - Norton Summit 1					Average Speed	59.40 km/h
Distance		Direction	Information	Distance To Go		
Total	Part					
0.00	0.00	 1 5.49	  Start S 34° 54.492 E 138° 41.446	26.73		
0.81	0.81	 2 4.68	RGHL	25.92		
1.05	0.24	 3 4.44	RGR	25.68		
1.32	0.27	 4 4.17	RGL	25.41		
1.48	0.16	 5 4.01	RGR then RGHR	25.25		
2.48	1.00	 6 3.01	RGHL	24.25		



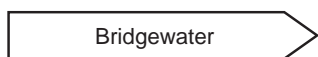

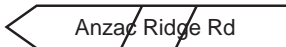
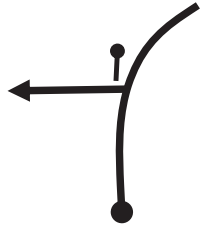

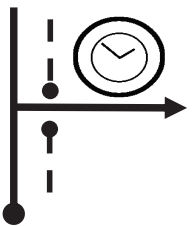
Day 2	Your Start Time	Time Allowed	Due Time @ TC		Total Distance	26.73 km
Section 2	: : :	0:27:00	: : :		SS Distance	5.49 km
TC 15	Norton Summit Road				Time Allowed	0:27:00 mins
TC 15A	Bridgewater Oval				Average Speed	59.40 km/h
SS 15 - Norton Summit 1						
Distance		Direction	Information	Distance To Go		
Total	Part					
3.15	0.67	 7 2.34	RGR and tightens	23.58		
4.30	1.15	 8 1.19	Start VC S 34° 54.738 E 138° 42.815	22.43		
4.50	0.20	 9 0.99	End VC S 34° 54.819 E 138° 42.890	22.23		
4.74	0.24	 10 0.75	RGR Keep in on Exit	21.99		
4.90	0.16	 11 0.59	Start VC then 50m SO over Crest S 34° 54.967 E 138° 43.040	21.83		



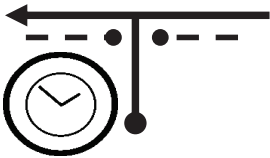

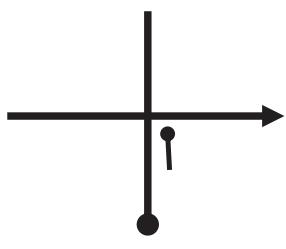
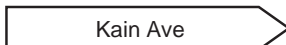
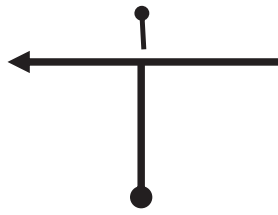
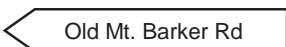

Day 2	Your Start Time	Time Allowed	Due Time @ TC		Total Distance	26.73 km
Section 2	: : :	0:27:00	: : :		SS Distance	5.49 km
TC 15	Norton Summit Road				Time Allowed	0:27:00 mins
TC 15A	Bridgewater Oval				Average Speed	59.40 km/h
SS 15 - Norton Summit 1						
Distance		Direction	Information	Distance To Go		
Total	Part					
5.10	0.20	<p>12 0.39</p>	<p>End VC</p> <p>S 34° 55.042 E 138° 43.152</p>	21.63		
5.25	0.15	<p>13 0.24</p>	<p>RGL</p>	21.48		
5.49	0.24	<p>14 0.00</p>	<p>Flying Finish</p> <p>S 34° 55.132 E 138° 43.330</p>	21.24		
5.81	0.32	<p>15 0.00</p>	<p>Stop Point</p> <p>S 34° 55.255 E 138° 43.433</p>	20.92		
6.09	0.28	<p>16 0.00</p>	<p>STOP then SO on Main Road</p> <p>← Lobethal</p>	20.64		
7.04	0.95	<p>17 0.00</p>	<p>! Care TR Hard to See</p> <p>Woods Hill Rd →</p>	19.69		

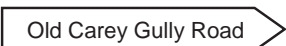
Day 2	Your Start Time	Time Allowed	Due Time @ TC		Total Distance	26.73 km
Section 2	: : :	0:27:00	: : :		SS Distance	5.49 km
TC 15	Norton Summit Road				Time Allowed	0:27:00 mins
TC 15A	Bridgewater Oval				Average Speed	59.40 km/h
SS 15 - Norton Summit 1						
Distance		Direction	Information	Distance To Go		
Total	Part					
8.94	1.90	<p>18</p>	<p>STOP then SO @ XR</p> <p>Stony Rise Rd</p>	17.79		
10.62	1.68	<p>19</p>	<p>GIVE WAY then TL @ XR</p> <p>Greenhill Rd</p>	16.11		
Continue through Summertown and Uraidla.						
19.48	8.86	<p>20</p>	<p>TR</p> <p>Beaumont Rd</p>	7.25		
19.89	0.41	<p>21</p>	<p>RGR then 20m SO</p> <p>Tanamerah Rd</p>	6.84		
22.43	2.54	<p>22</p>	<p>TR @ TJ</p> <p>Onkaparinga Valley Rd</p>	4.30		

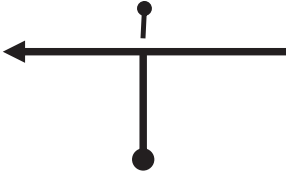
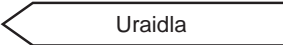
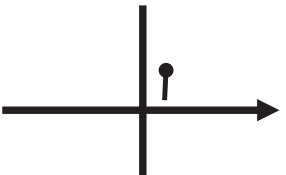
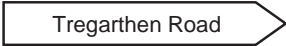
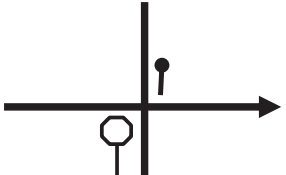
Day 2	Your Start Time	Time Allowed	Due Time @ TC			
Section 2	: : :	0:27:00	: : :		Total Distance	26.73 km
TC 15	Norton Summit Road				SS Distance	5.49 km
TC 15A	Bridgewater Oval				Time Allowed	0:27:00 mins
SS 15 - Norton Summit 1					Average Speed	59.40 km/h
Distance		Direction	Information	Distance To Go		
Total	Part					
23.71	1.28	 23	SO @ Roundabout 	3.02		
26.27	2.56	 24	SO 	0.46		
26.67	0.40	 25	TL 	0.06		
26.73	0.06	 26	TR thru gate then TC In	0.00		

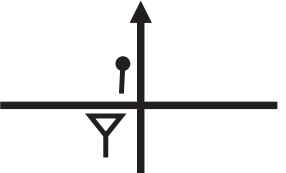
Day 2 Section 3	Your Start Time : : :	Time Allowed 0:18:00	Due Time @ TC : : :		Total Distance	17.21 km
TC 15B TC 16	Bridgewater Oval Pound Road				Time Allowed	0:18:00
LIASON ONLY					Average Speed	57.37 km/h

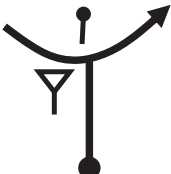
Distance		Direction	Information	Distance To Go
Total	Part			
0.00	0.00	 <p>1</p>	 TC Out TL thru Gate	17.21
0.04	0.04	 <p>2</p>	TL @ TJ	17.17
0.12	0.08	 <p>3</p>	SO 	17.09
1.05	0.93	 <p>4</p>	TR @ XR 	16.16
1.45	0.40	 <p>5</p>	TL @ TJ 	15.76
3.64	2.19	 <p>6</p>	TR ! Care Hard to See 	13.57

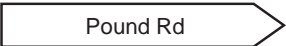
Day 2	Your Start Time	Time Allowed	Due Time @ TC		Total Distance	17.21 km
Section 3	: : :	0:18:00	: : :			
TC 15B	Bridgewater Oval				Time Allowed	0:18:00
TC 16	Pound Road				Average Speed	57.37 km/h
LIASON ONLY						
Distance		Direction	Information	Distance To Go		
Total	Part					
9.11	5.47	 7	TL @ TJ 	8.10		
Continue on Greenhill Road through Uraidla and Summertown.						
13.14	4.03	 8	TR @ XR 	4.07		
14.82	1.68	 9	STOP then TR @ XR 	2.39		
15.72	0.90	 10	GIVE WAY then SO @ XR 	1.49		
16.32	0.60	 11	GIVE WAY then TR @ TJ 	0.89		
16.94	0.62	 12	TR 	0.27		

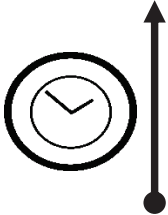
Day 2	Your Start Time	Time Allowed	Due Time @ TC		Total Distance	17.21 km
Section 3	: :	0:18:00	: :			
TC 15B	Bridgewater Oval					
TC 16	Pound Road				Time Allowed	0:18:00
LIASON ONLY					Average Speed	57.37 km/h
Distance		Direction		Information		Distance To Go
Total	Part					
17.21	0.27			TC In then 30m Start		0.00
		13				





Day 2	Your Start Time	Time Allowed	Due Time @ TC		Total Distance	37.46 km
Section 3	: :	0:42:00	: :		SS Distance	10.36 km
TC 16	Pound Road				Time Allowed	0:42:00
TC 17	Tippett Road				Average Speed	53.51 km/h
SS 16 - Knotts Range						

Distance		Direction	Information	Distance To Go
Total	Part			

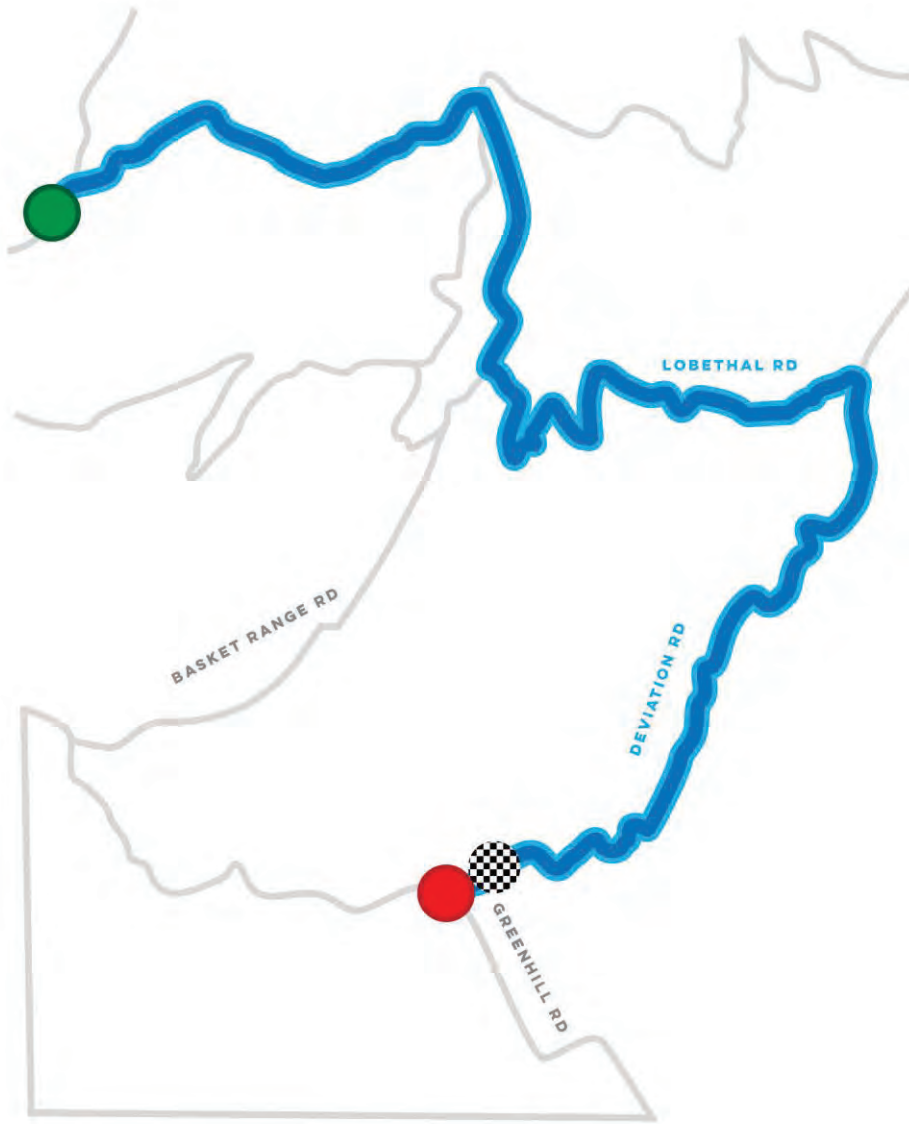

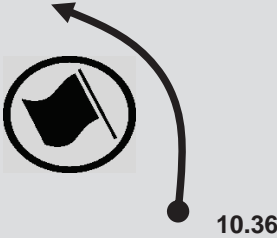
SS16

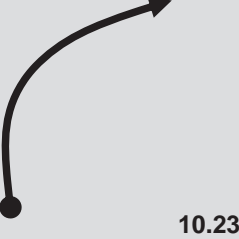
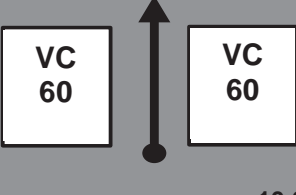
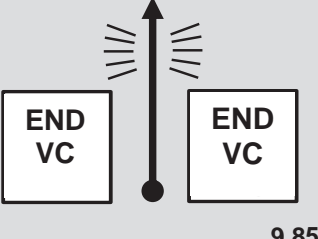
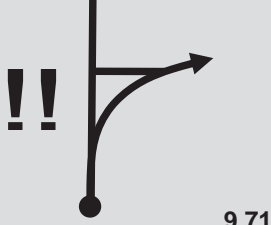
KNOTTS RANGE



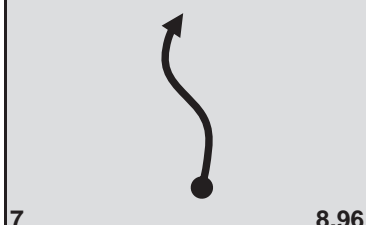
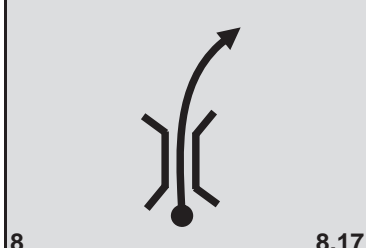
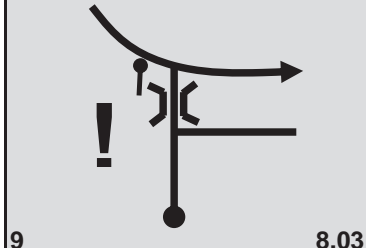
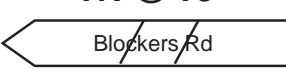
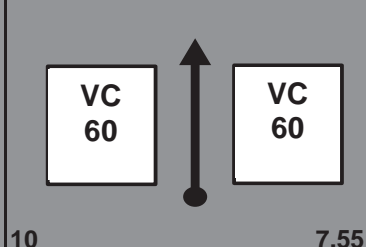
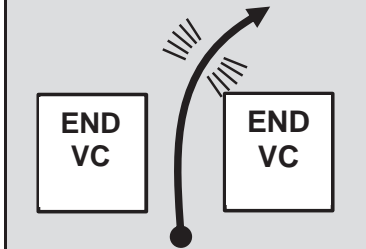
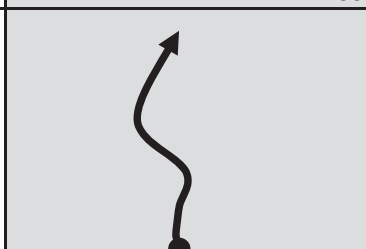



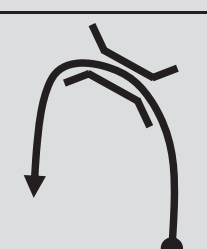
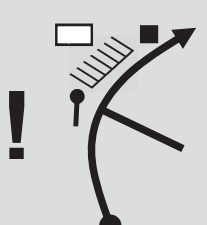
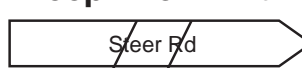
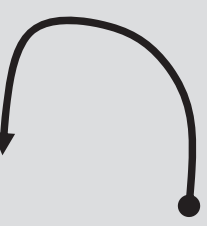
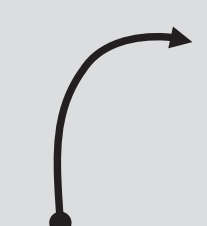



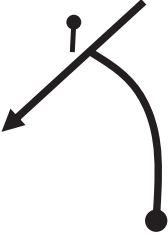

Day 2		Your Start Time	Time Allowed	Due Time @ TC			
Section 3		: :	0:42:00	: :	Total Distance	37.46 km	
TC 16	Pound Road				SS Distance	10.36 km	
TC 17	Tippett Road				Time Allowed	0:42:00	
SS 16 - Knotts Range					Average Speed	53.51 km/h	
Distance		Direction			Information		Distance To Go
Total	Part						
0.00	0.00	 1 10.36			  Start then 30m RGL S 34° 55.861 E 138° 44.850		37.46
0.13	0.13	 2 10.23			RGR		37.33
0.31	0.18	 3 10.05			Start VC S 34° 55.777 E 138° 45.008		37.15
0.51	0.20	 4 9.85			SO over Crest End VC S 34° 55.711 E 138° 45.115		36.95
0.65	0.14	 5 9.71			!! Caution KR then RGR  S 34° 55.683 E 138° 45.186		36.81
1.09	0.44	 6 9.27			RGR Keep in on Exit		36.37

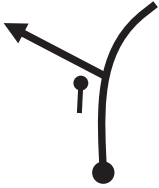
Day 2	Your Start Time	Time Allowed	Due Time @ TC			
Section 3	: : :	0:42:00	: : :		Total Distance	37.46 km
TC 16	Pound Road				SS Distance	10.36 km
TC 17	Tippett Road				Time Allowed	0:42:00
SS 16 - Knotts Range					Average Speed	53.51 km/h
Distance		Direction	Information	Distance To Go		
Total	Part					
1.40	0.31	 7 8.96	RGL then RGR	36.06		
2.19	0.79	 8 8.17	Bumpy Bridge then RGR	35.27		
2.33	0.14	 9 8.03	! Care Bridge then TR @ TJ  S 34° 55.650 E 138° 46.084	35.13		
2.81	0.48	 10 7.55	Start VC S 34° 55.890 E 138° 46.251	34.65		
3.01	0.20	 11 7.35	End VC then RGR on Crest Keep in on Exit S 34° 55.997 E 138° 46.257	34.45		
3.43	0.42	 12 6.93	RGL then RGR	34.03		

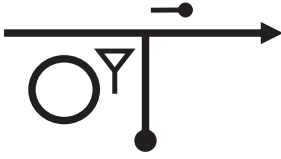
Day 2	Your Start Time	Time Allowed	Due Time @ TC			
Section 3	: : :	0:42:00	: : :			
TC 16	Pound Road				Total Distance	37.46 km
TC 17	Tippett Road				SS Distance	10.36 km
SS 16 - Knotts Range					Time Allowed	0:42:00
					Average Speed	53.51 km/h
Distance		Direction	Information	Distance To Go		
Total	Part					
3.80	0.37	 13 6.56	! Care TL @ TJ over Brow  Lobethal S 34° 56.377 E 138° 46.163	33.66		
4.01	0.21	 14 6.35	! Care RGR Keep in on Exit S 34° 56.462 E 138° 46.256	33.45		
4.34	0.33	 15 6.02	RGL over Bridge and Tightens	33.12		
4.70	0.36	 16 5.66	! Care RGHR Keep in on Exit  Steer Rd S 34° 56.498 E 138° 46.367	32.76		
4.96	0.26	 17 5.40	RGL	32.50		
5.30	0.34	 18 5.06	RGR	32.16		

Day 2		Your Start Time	Time Allowed	Due Time @ TC		Total Distance	37.46 km
Section 3		: :	0:42:00	: :		SS Distance	10.36 km
TC 16	Pound Road					Time Allowed	0:42:00
TC 17	Tippett Road					Average Speed	53.51 km/h
SS 16 - Knotts Range							
Distance		Direction			Information		Distance To Go
Total	Part						
6.94	1.64	 19 3.42			!! Caution TVHR SOS A S 34° 56.385 E 138° 47.411		30.52
7.36	0.42	 20 3.00			RGR Keep in on Exit		30.10
7.96	0.60	 21 2.40			RGL and Tightens		29.50
8.31	0.35	 22 2.05			RGR Keep in on Exit		29.15
8.48	0.17	 23 1.88			RGR then RGL		28.98
8.76	0.28	 24 1.60			Start VC S 34° 57.093 E 138° 46.966		28.70

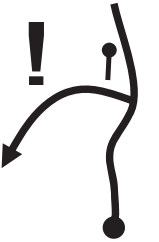
Day 2	Your Start Time	Time Allowed	Due Time @ TC			
Section 3	: : :	0:42:00	: : :		Total Distance	37.46 km
TC 16	Pound Road				SS Distance	10.36 km
TC 17	Tippett Road				Time Allowed	0:42:00
SS 16 - Knotts Range					Average Speed	53.51 km/h
Distance		Direction	Information	Distance To Go		
Total	Part					
8.96	0.20		<p>End VC then RGR then RGL Keep in on Exit</p> <p>S 34° 57.200 E 138° 46.916</p>	28.50		
9.66	0.70		<p>Start VC</p> <p>S 34° 57.532 E 138° 46.782</p>	27.80		
9.86	0.20		<p>End VC then ! Care RGHR Keep in on Exit</p> <p>S 34° 57.638 E 138° 46.717</p>	27.60		
10.17	0.31		<p>RGR then RGHL</p>	27.29		
10.36	0.19		<p>Flying Finish</p> <p>S 34° 57.714 E 138° 46.495</p>	27.10		
10.58	0.22		<p>Stop Point</p> <p>S 34° 57.751 E 138° 46.369</p>	26.88		

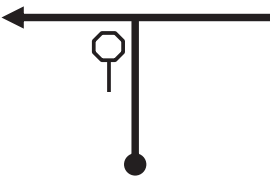

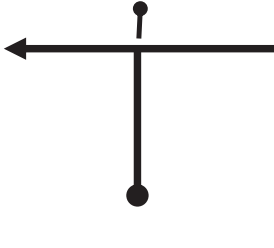
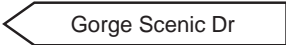
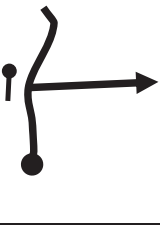
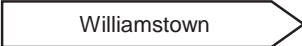
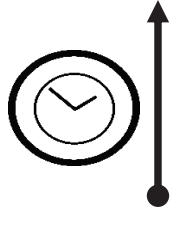



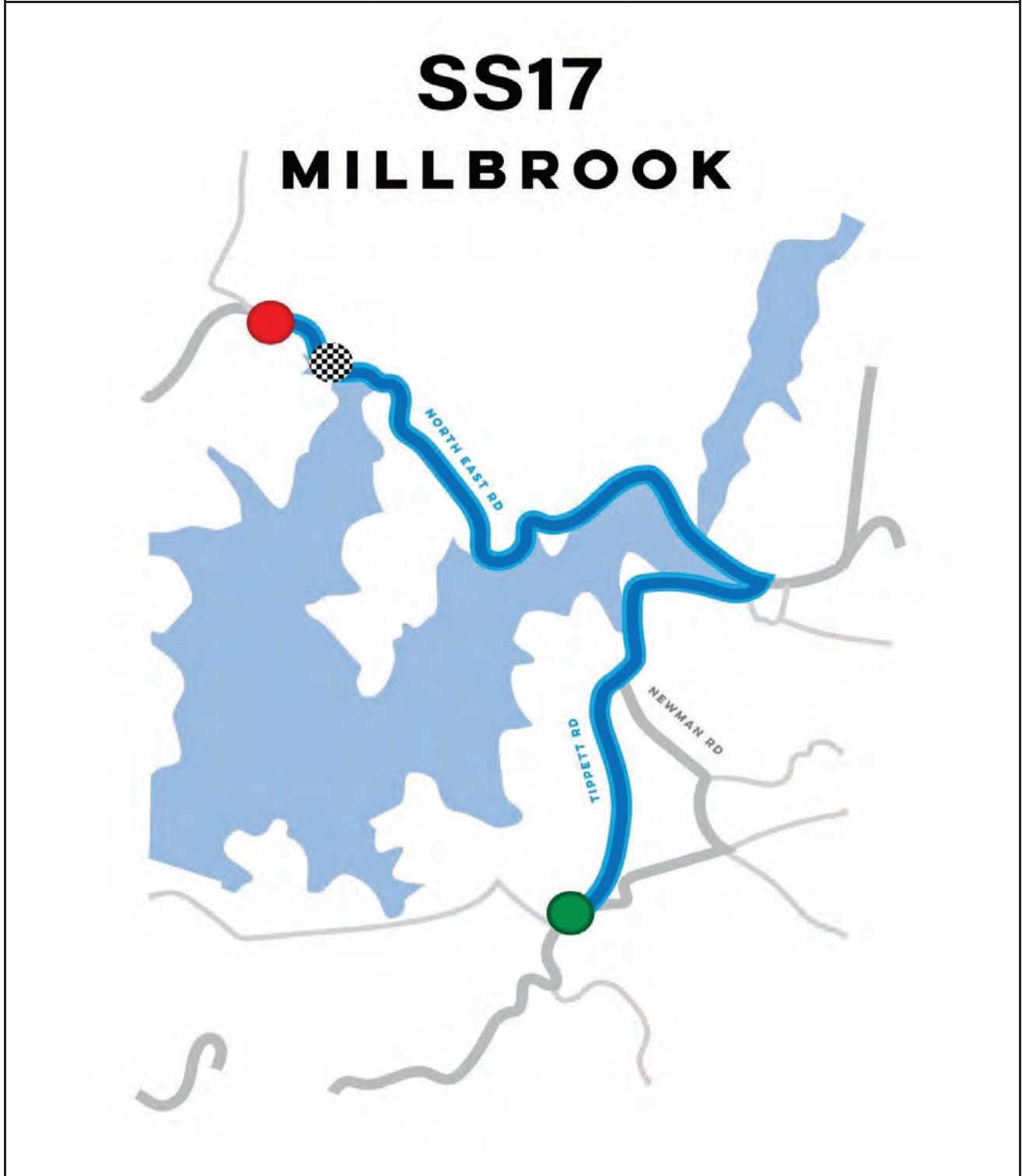

Day 2	Your Start Time	Time Allowed	Due Time @ TC			
Section 3	: : :	0:42:00	: : :			
TC 16	Pound Road				Total Distance	37.46 km
TC 17	Tippett Road				SS Distance	10.36 km
SS 16 - Knotts Range					Time Allowed	0:42:00
					Average Speed	53.51 km/h
Distance		Direction	Information	Distance To Go		
Total	Part					
11.19	0.61	 31	TL @ TJ 	26.27		
17.06	5.87	 32	TL 	20.40		
22.79	5.73	 33	GIVE WAY then TR @ TJ (Fred's Tank) 	14.67		
25.50	2.71	 34	GIVE WAY then TR @ TJ 	11.96		
26.03	0.53	 35	! Care TL Hard to See 	11.43		
33.86	7.83	 36	STOP then TL @ TJ	3.60		

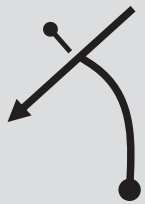

Day 2 Section 3	Your Start Time : : :	Time Allowed 0:42:00	Due Time @ TC : : :		Total Distance	37.46 km
TC 16 TC 17	Pound Road Tippett Road				SS Distance	10.36 km
					Time Allowed	0:42:00
SS 16 - Knotts Range					Average Speed	53.51 km/h
Distance		Direction	Information	Distance To Go		
Total	Part					
35.66	1.80		<p>TL @ TJ</p> 	1.80		
36.96	1.30		<p>TR @ RJ</p> 	0.50		
37.46	0.50		<p>TC In then 30m Start</p>	0.00		

Day 2	Your Start Time	Time Allowed	Due Time @ TC			
Section 3	: : :	0:15:00	: : :		Total Distance	12.08 km
TC 17	Tippett Road				SS Distance	3.99 km
TC 18	Lower North East Road				Time Allowed	0:15:00
SS 17 - Millbrook					Average Speed	48.32 km/h

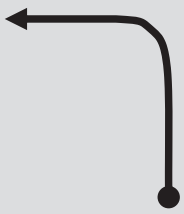
Distance		Direction	Information	Distance To Go
Total	Part			

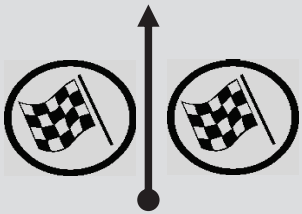
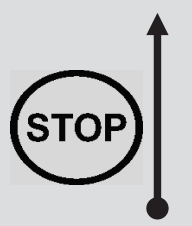
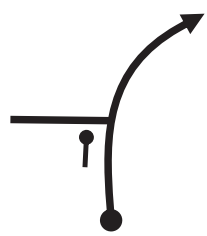
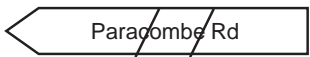
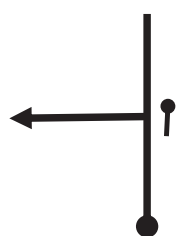
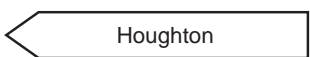

Day 2	Your Start Time	Time Allowed	Due Time @ TC			
Section 3	: : :	0:15:00	: : :		Total Distance	12.08 km
TC 17	Tippett Road				SS Distance	3.99 km
TC 18	Lower North East Road				Time Allowed	0:15:00
SS 17 - Millbrook					Average Speed	48.32 km/h
Distance		Direction	Information	Distance To Go		
Total	Part					
0.00	0.00	 1 3.99	   Start S 34° 50.003 E 138° 49.437	12.08		
0.44	0.44	 2 3.55	! Care RGR on Crest S 34° 49.760 E 138° 49.440	11.64		
1.51	1.07	 3 2.48	RGL then TL @ TJ 	10.57		
2.12	0.61	 4 1.87	RGL	9.96		
3.10	0.98	 5 0.89	Crest	8.98		
3.58	0.48	 6 0.41	RGL then RGR	8.50		

Day 2	Your Start Time	Time Allowed	Due Time @ TC			
Section 3	: : :	0:15:00	: : :		Total Distance	12.08 km
TC 17	Tippett Road				SS Distance	3.99 km
TC 18	Lower North East Road				Time Allowed	0:15:00
SS 17 - Millbrook					Average Speed	48.32 km/h
Distance		Direction	Information	Distance To Go		
Total	Part					
3.99	0.41	 7 0.00	Flying Finish S 34° 48.954 E 138° 48.778	8.09		
4.23	0.24	 8	Stop Point then FMR S 34° 48.894 E 138° 48.657	7.85		
7.73	3.50	 9	SO 	4.35		
9.35	1.62	 10	TL Hard to See 	2.73		
9.97	0.62	 11	KR FMR	2.11		









Day 2	Your Start Time	Time Allowed	Due Time @ TC			
Section 3	: : :	0:15:00	: : :		Total Distance	12.08 km
TC 17	Tippett Road				SS Distance	3.99 km
TC 18	Lower North East Road				Time Allowed	0:15:00
SS 17 - Millbrook					Average Speed	48.32 km/h
Distance		Direction	Information	Distance To Go		
Total	Part					
11.93	1.96	<p>12</p>	<p>SO</p>	0.15		
12.08	0.15	<p>13</p>	<p>TC IN then 30m SO @ XR then 30m Start</p>	0.00		

Day 2	Your Start Time	Time Allowed	Due Time @ TC			
Section 3	: : :	0:16:00	: : :			
TC 18	Lower North East Road				Total Distance	14.19 km
TC 18A	Foxfield Oval				SS Distance	2.60 km
SS 18 - Vista 2					Time Allowed	0:16:00
					Average Speed	53.21 km/h

Distance		Direction	Information	Distance To Go
Total	Part			

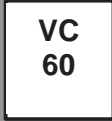
SS18 VISTA 2

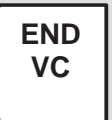
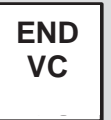



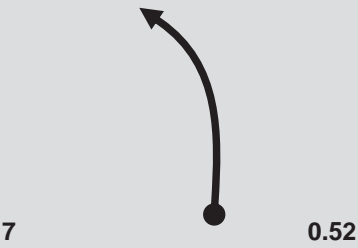
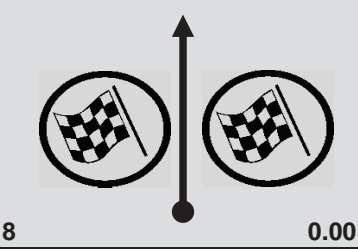
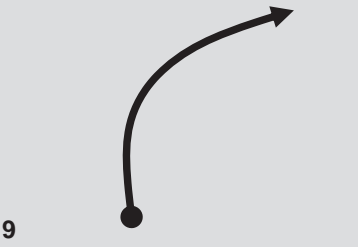
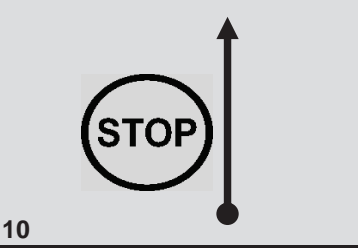
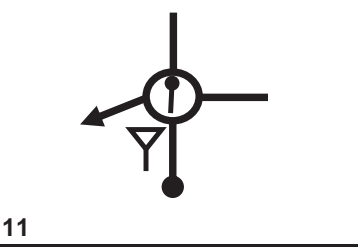
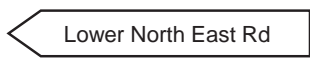



Day 2	Your Start Time	Time Allowed	Due Time @ TC			
Section 3	: : :	0:16:00	: : :		Total Distance	14.19 km
TC 18	Lower North East Road				SS Distance	2.60 km
TC 18A	Foxfield Oval				Time Allowed	0:16:00
SS 18 - Vista 2					Average Speed	53.21 km/h
Distance		Direction	Information	Distance To Go		
Total	Part					
0.00	0.00	 1 2.60	  Start S 34° 50.446 E 138° 44.804	14.19		
0.78	0.78	 2 1.82	RGL	13.41		
0.82	0.04	  3 1.78	 Start VC S 34° 50.419 E 138° 44.285	13.37		
1.02	0.20	  4 1.58	End VC S 34° 50.480 E 138° 44.171	13.17		
1.36	0.34	 5 1.24	Bump as RGL then 100m !! Caution RGHR S 34° 50.589 E 138° 43.909	12.83		
1.80	0.44	 6 0.80	RGL then RGR	12.39		

Day 2	Your Start Time	Time Allowed	Due Time @ TC		Total Distance	14.19 km
Section 3	: :	0:16:00	: :		SS Distance	2.60 km
TC 18	Lower North East Road				Time Allowed	0:16:00
TC 18A	Foxfield Oval				Average Speed	53.21 km/h
SS 18 - Vista 2						
Distance		Direction	Information	Distance To Go		
Total	Part					
2.08	0.28		RGL	12.11		
2.60	0.52		Flying Finish S 34° 50.261 E 138° 43.576	11.59		
2.87	0.27		RGR	11.32		
3.02	0.15		Stop Point S 34° 50.410 E 138° 43.421	11.17		
3.34	0.32		GIVE WAY then TL @ Roundabout 	10.85		
FMR to Darley Road, passing over George Street.						

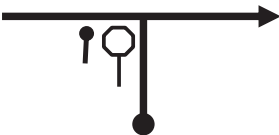
Day 2	Your Start Time	Time Allowed	Due Time @ TC			
Section 3	: : :	0:16:00	: : :			
TC 18	Lower North East Road				Total Distance	14.19 km
TC 18A	Foxfield Oval				SS Distance	2.60 km
SS 18 - Vista 2					Time Allowed	0:16:00
					Average Speed	53.21 km/h
Distance		Direction	Information	Distance To Go		
Total	Part					
9.81	6.47	<p>12</p>	<p>TL @ XR</p> <p>Darley Rd</p>	4.38		
10.18	0.37	<p>13</p>	<p>TL @ XR</p> <p>Gorge Rd</p>	4.01		
12.03	1.85	<p>14</p>	<p>Move to Left lane</p> <p>GIVE WAY then</p> <p>SO @ Roundabout</p>	2.16		
13.04	1.01	<p>15</p>	<p>TR</p> <p>Maryvale Rd</p>	1.15		
14.19	1.15	<p>16</p>	<p>TL into Oval</p> <p>then TC In</p> <p>Follow direction of</p> <p>Officials</p>	0.00		

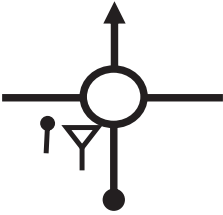
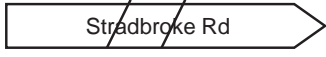
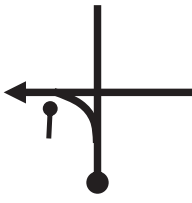
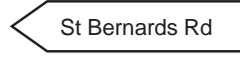
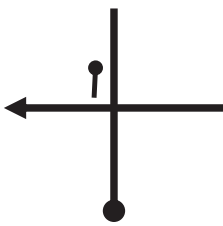
Day 2	Your Start Time	Time Allowed	Due Time @ TC		Total Distance	7.39 km
Section 4	: : :	0:10:00	: : :			
TC 18B	Foxfield Oval					
TC 19	Norton Summit Road				Time Allowed	0:10:00
LIASON ONLY					Average Speed	44.34 km/h

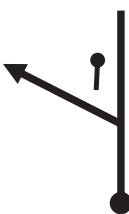
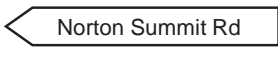
Distance		Direction	Information	Distance To Go
Total	Part			
0.00	0.00	 1	 TC Out TL onto Main Road	7.39
0.52	0.52	 2	STOP then TR @ TJ FMR 	6.87
1.32	0.80	 3	GIVE WAY then SO @ Roundabout 	6.07
2.99	1.67	 4	TL @ XR 	4.40
5.69	2.70	 5	TL @ XR 	1.70
6.14	0.45	 6	TL 	1.25

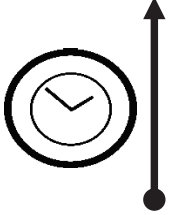
Day 2 Section 4	Your Start Time : : :	Time Allowed 0:10:00	Due Time @ TC : : :		Total Distance	7.39 km
TC 18B	Foxfield Oval					
TC 19	Norton Summit Road				Time Allowed	0:10:00
LIASON ONLY					Average Speed	44.34 km/h
Distance		Direction		Information		Distance To Go
Total	Part					
7.39	1.25			TC In then 30m Start		0.00
		7				









Day 2	Your Start Time	Time Allowed	Due Time @ TC			
Section 4	: : :	0:26:00	: : :		Total Distance	21.88 km
TC 19	Norton Summit Road				SS Distance	5.49 km
TC 19A	Aldgate Main Street				Time Allowed	0:26:00 mins
SS 19 - Norton Summit 2					Average Speed	50.49 km/h

Distance		Direction	Information	Distance To Go
Total	Part			

SS19

NORTON SUMMIT 2



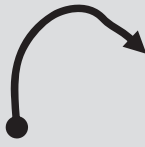
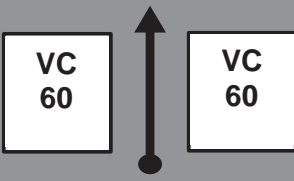
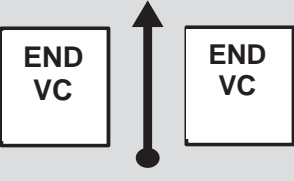
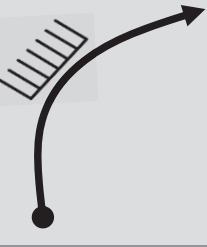
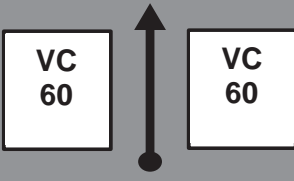

Day 2	Your Start Time	Time Allowed	Due Time @ TC			
Section 4	: : :	0:26:00	: : :		Total Distance	21.88 km
TC 19	Norton Summit Road				SS Distance	5.49 km
TC 19A	Aldgate Main Street				Time Allowed	0:26:00 mins
SS 19 - Norton Summit 2					Average Speed	50.49 km/h
Distance		Direction	Information	Distance To Go		
Total	Part					
0.00	0.00	 1 5.49	  Start S 34° 54.492 E 138° 41.446	21.88		
0.81	0.81	 2 4.68	RGHL	21.07		
1.05	0.24	 3 4.44	RGR	20.83		
1.32	0.27	 4 4.17	RGL	20.56		
1.48	0.16	 5 4.01	RGR then RGHR	20.40		
2.48	1.00	 6 3.01	RGHL	19.40		

Day 2	Your Start Time	Time Allowed	Due Time @ TC			
Section 4	: : :	0:26:00	: : :		Total Distance	21.88 km
TC 19	Norton Summit Road				SS Distance	5.49 km
TC 19A	Aldgate Main Street				Time Allowed	0:26:00 mins
SS 19 - Norton Summit 2					Average Speed	50.49 km/h
Distance		Direction	Information	Distance To Go		
Total	Part					
3.15	0.67	 7 2.34	RGR and tightens	18.73		
4.30	1.15	 8 1.19	Start VC S 34° 54.738 E 138° 42.815	17.58		
4.50	0.20	 9 0.99	End VC S 34° 54.819 E 138° 42.890	17.38		
4.74	0.24	 10 0.75	RGR Keep in on Exit	17.14		
4.90	0.16	 11 0.59	Start VC then 50m SO over Crest S 34° 54.967 E 138° 43.040	16.98		

Day 2	Your Start Time	Time Allowed	Due Time @ TC			
Section 4	: : :	0:26:00	: : :		Total Distance	21.88 km
TC 19	Norton Summit Road				SS Distance	5.49 km
TC 19A	Aldgate Main Street				Time Allowed	0:26:00 mins
SS 19 - Norton Summit 2					Average Speed	50.49 km/h
Distance		Direction	Information	Distance To Go		
Total	Part					
5.10	0.20		<p>End VC</p> <p>S 34° 55.042 E 138° 43.152</p>	16.78		
5.25	0.15		<p>RGL</p>	16.63		
5.49	0.24		<p>Flying Finish</p> <p>S 34° 55.132 E 138° 43.330</p>	16.39		
5.81	0.32		<p>Stop Point</p> <p>S 34° 55.255 E 138° 43.433</p>	16.07		
6.09	0.28		<p>STOP then SO on Main Road</p> <p>← Lobethal</p>	15.79		
7.04	0.95		<p>! Care TR Hard to See</p> <p>→ Woods Hill Rd</p>	14.84		

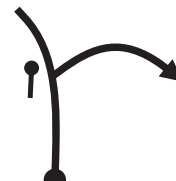
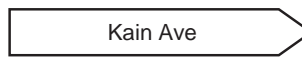
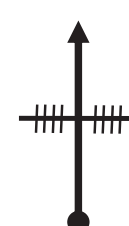
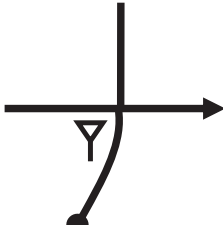
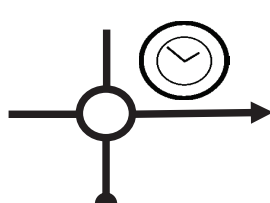
Day 2	Your Start Time	Time Allowed	Due Time @ TC			
Section 4	: :	0:26:00	: :		Total Distance	21.88 km
TC 19	Norton Summit Road				SS Distance	5.49 km
TC 19A	Aldgate Main Street				Time Allowed	0:26:00 mins
SS 19 - Norton Summit 2					Average Speed	50.49 km/h
Distance		Direction	Information	Distance To Go		
Total	Part					
8.97	1.93	<p>18</p>	<p>STOP then SO @ XR</p> <p>Stony Rise Rd</p>	12.91		
10.64	1.67	<p>19</p>	<p>GIVE WAY then TL @ XR</p> <p>Greenhill Rd</p>	11.24		
11.27	0.63	<p>20</p>	<p>TR</p> <p>Crafers</p> <p>FMR</p> <p>Picadilly Rd</p>	10.61		
16.09	4.82	<p>21</p>	<p>GIVE WAY then TL @ Roundabout</p> <p>Stirling East</p>	5.79		
17.26	1.17	<p>22</p>	<p>TL</p> <p>Old Mount Barker Rd</p>	4.62		

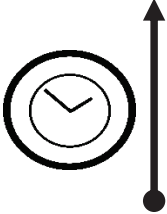
Day 2	Your Start Time	Time Allowed	Due Time @ TC			
Section 4	: : :	0:26:00	: : :		Total Distance	21.88 km
TC 19	Norton Summit Road				SS Distance	5.49 km
TC 19A	Aldgate Main Street				Time Allowed	0:26:00 mins
SS 19 - Norton Summit 2					Average Speed	50.49 km/h
Distance		Direction	Information	Distance To Go		
Total	Part					
20.09	2.83	 23	<p>TR</p> 	1.79		
20.25	0.16	 24	<p>Railway Crossing SO</p>	1.63		
20.51	0.26	 25	<p>GIVE WAY then TR @ XR</p>	1.37		
21.88	1.37	 26	<p>TR @ Roundabout then TC In</p>	0.00		

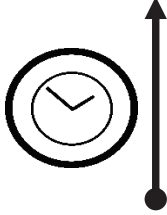
Day 2 Section 5	Your Start Time : : :	Time Allowed 0:01:00	Due Time @ TC : : :		Total Distance	0.03 km
TC 19B	Aldgate Main Street					
TC 20	Mount Barker Road				Time Allowed	0:01:00
LIASON ONLY					Average Speed	1.80 km/h
Distance		Direction	Information	Distance To Go		
Total	Part					
0.00	0.00	 1	 TC Out SO	0.03		
0.03	0.03	 2	TC In then 30m Start	0.00		









Day 2	Your Start Time	Time Allowed	Due Time @ TC			
Section 5	: : :	0:10:00	: : :		Total Distance	6.40 km
TC 20	Mount Barker Road				SS Distance	0.83 km
TC 21	Mount Barker Road				Time Allowed	0:10:00
SS 20 - Wairoa					Average Speed	38.40 km/h



Distance		Direction	Information	Distance To Go
Total	Part			

SS20 WAIROA

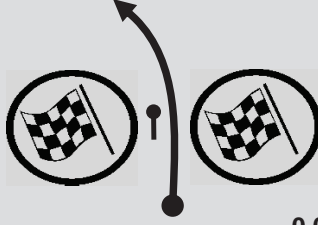

Day 2	Your Start Time	Time Allowed	Due Time @ TC		Total Distance	6.40 km
Section 5	: : :	0:10:00	: : :		SS Distance	0.83 km
TC 20	Mount Barker Road				Time Allowed	0:10:00
TC 21	Mount Barker Road				Average Speed	38.40 km/h
SS 20 - Wairoa						

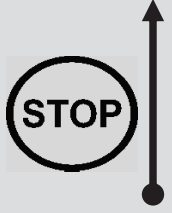
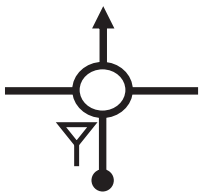
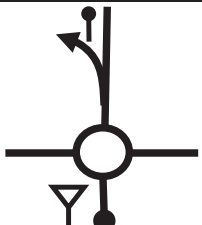
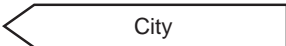
Distance		Direction	Information	Distance To Go
Total	Part			
0.00	0.00	 1 0.83	   Start S 35° 00.851 E 138° 44.066	6.40
0.11	0.11	 2 0.72	Slow Point S 35° 00.824 E 138° 44.002	6.29
0.18	0.07	 3 0.65	! Care RGR on Hump then RGL S 35° 00.806 E 138° 43.945	6.22
0.30	0.12	 4 0.53	RGR then Tightens	6.10
0.65	0.35	 5 0.18	Slow Point S 35° 00.609 E 138° 43.814	5.75
0.83	0.18	 6 0.00	Flying Finish S 35° 00.526 E 138° 43.759	5.57

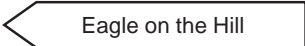
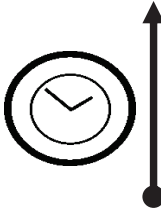
Day 2	Your Start Time	Time Allowed	Due Time @ TC			
Section 5	: : :	0:10:00	: : :			
TC 20	Mount Barker Road				Total Distance	6.40 km
TC 21	Mount Barker Road				SS Distance	0.83 km
SS 20 - Wairoa					Time Allowed	0:10:00
					Average Speed	38.40 km/h
Distance		Direction	Information	Distance To Go		
Total	Part					
1.02	0.19	 7	Stop Point S 35° 00.501 E 138° 43.649	5.38		
1.94	0.92	 8	GIVE WAY then SO @ Roundabout	4.46		
2.30	0.36	 9	GIVE WAY then SO @ Roundabout then 50m KL 	4.10		
Merge onto the South Eastern Freeway, and continue past the Crafers Exit.						
5.10	2.80	 10	Take Exit Ramp on L 	1.30		
6.40	1.30	 11	TC In then 30m Start	0.00		









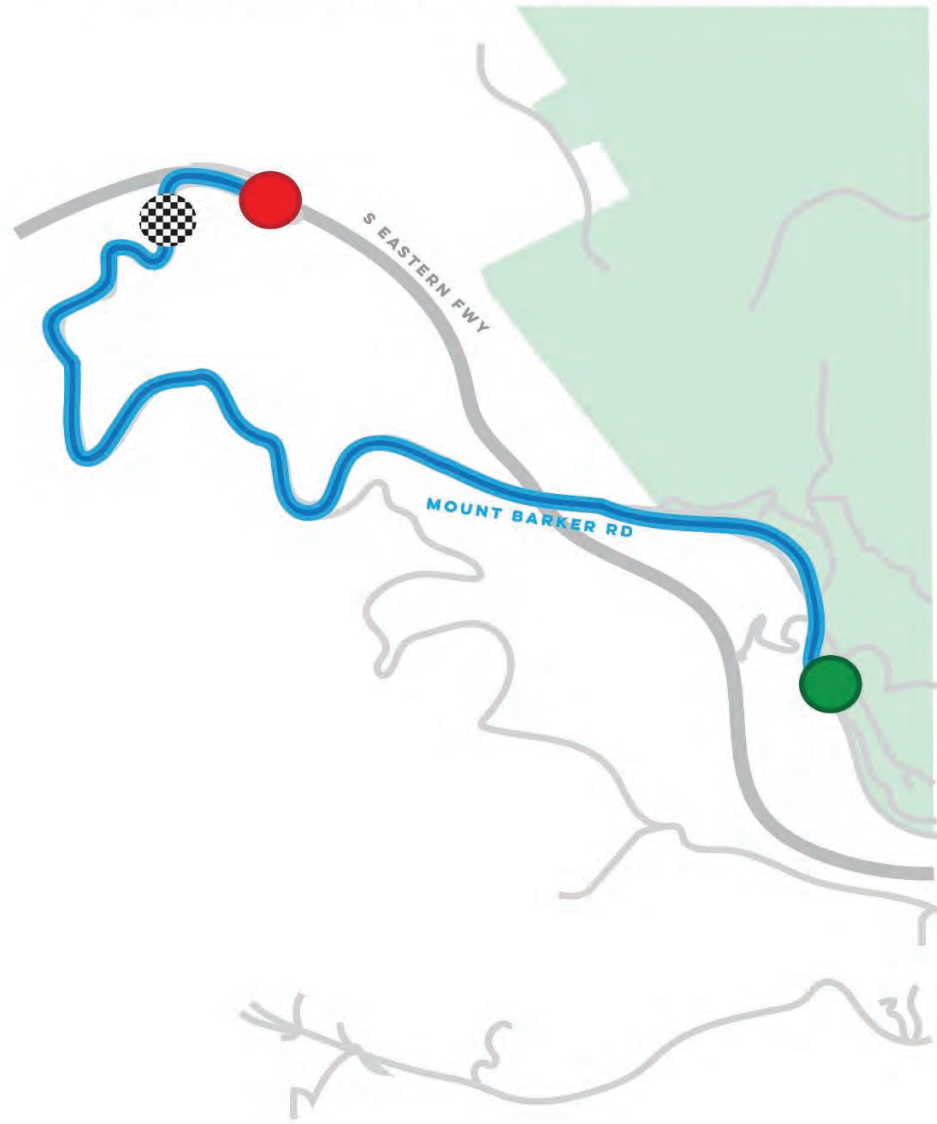

Day 2	Your Start Time	Time Allowed	Due Time @ TC			
Section 5	: : :	0:13:00	: : :		Total Distance	14.57 km
TC 21	Mount Barker Road				SS Distance	3.62 km
TC 22	Belair Road				Time Allowed	0:13:00
SS 21 - Leawood Gardens					Average Speed	67.25 km/h

Distance		Direction	Information	Distance To Go
Total	Part			

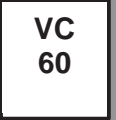
SS21

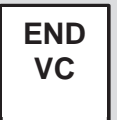
LEAWOOD GARDENS

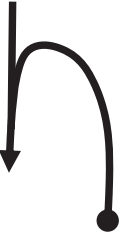

Day 2	Your Start Time	Time Allowed	Due Time @ TC			
Section 5	: : :	0:13:00	: : :		Total Distance	14.57 km
TC 21	Mount Barker Road				SS Distance	3.62 km
TC 22	Belair Road				Time Allowed	0:13:00
SS 21 - Leawood Gardens					Average Speed	67.25 km/h
Distance		Direction	Information	Distance To Go		
Total	Part					
0.00	0.00	 1 3.62	  Start S 34° 58.792 E 138° 41.197	14.57		
0.79	0.79	  2 2.83	Start VC S 34° 58.560 E 138° 40.879	13.78		
0.99	0.20	  3 2.63	End VC S 34° 58.540 E 138° 40.746	13.58		
3.62	2.63	  4 0.00	Flying Finish S 34° 58.123 E 138° 40.057	10.95		
3.99	0.37	 5	Stop Point S 34° 58.075 E 138° 40.224	10.58		
4.03	0.04	 6	Hairpin Left then 80m Merge onto Freeway	10.54		
Stay in the left lane to turn left onto Cross Road.						







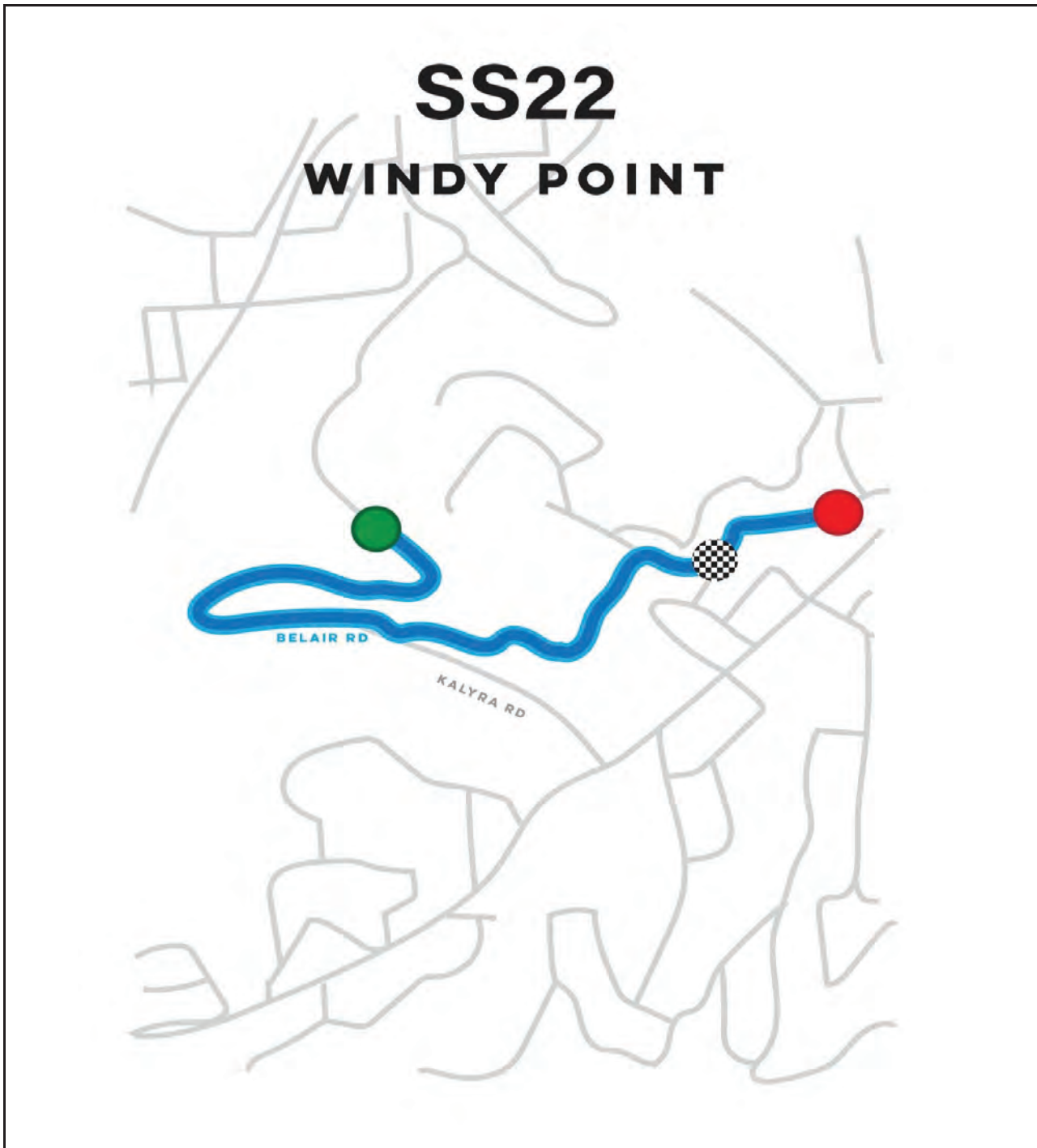

Day 2 Section 5	Your Start Time : : :	Time Allowed 0:13:00	Due Time @ TC : : :		Total Distance	14.57 km
TC 21 TC 22	Mount Barker Road Belair Road				SS Distance	3.62 km
					Time Allowed	0:13:00
SS 21 - Leawood Gardens					Average Speed	67.25 km/h
Distance		Direction	Information	Distance To Go		
Total	Part					
7.35	3.32	 7	TL @ XR 	7.22		
10.57	3.22	 8	TL @ XR 	4.00		
Continue on Belair Road, crossing over Tutt Avenue, Grange Road, Blythewood Road, and Springbank Road.						
14.57	4.00	 9	TC In then 30m Start	0.00		

Day 2	Your Start Time	Time Allowed	Due Time @ TC		
Section 5	: :	0:40:00	: :		Total Distance 14.97 km
TC 22	Belair Road				SS Distance 2.03 km
TC 22A	Gouger Street Party				Time Allowed 0:40:00
SS 22 - Windy Point					Average Speed 22.46 km/h

Distance		Direction	Information	Distance To Go
Total	Part			

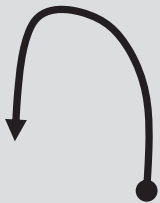

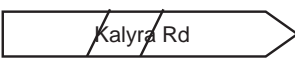
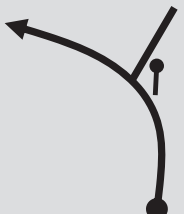
Day 2	Your Start Time	Time Allowed	Due Time @ TC		Total Distance	14.97 km
Section 5	: :	0:40:00	: :		SS Distance	2.03 km
TC 22	Belair Road				Time Allowed	0:40:00
TC 22A	Gouger Street Party				Average Speed	22.46 km/h
SS 22 - Windy Point						

Distance		Direction	Information	Distance To Go
Total	Part			
0.00	0.00	 1 2.03	  Start S 34° 59.918 E 138° 36.593	14.97
0.18	0.18	 2 1.85	RGHR	14.79
0.73	0.55	 3 1.30	RGL and Tightens	14.24
1.04	0.31	 4 0.99	SO @ XR 	13.93
1.62	0.58	 5 0.41	KL 	13.35

Day 2	Your Start Time	Time Allowed	Due Time @ TC		Total Distance	14.97 km
Section 5	: :	0:40:00	: :		SS Distance	2.03 km
TC 22	Belair Road				Time Allowed	0:40:00
TC 22A	Gouger Street Party				Average Speed	22.46 km/h
SS 22 - Windy Point						

Distance		Direction	Information	Distance To Go
Total	Part			
1.86	0.24	<p>6 0.17</p>	<p>KR</p> <p>Aerial Rd</p>	13.11
2.03	0.17	<p>7 0.00</p>	<p>Flying Finish</p> <p>S 34° 59.964 E 138° 37.063</p>	12.94
2.37	0.34	<p>8</p>	<p>Stop Point</p> <p>S 34° 59.903 E 138° 37.241</p>	12.60
2.52	0.15	<p>9</p>	<p>TL</p> <p>Russell St</p>	12.45
2.71	0.19	<p>10</p>	<p>STOP then TL then 40m KL</p> <p>Fullarton Rd</p>	12.26
4.90	2.19	<p>11</p>	<p>SO @ Roundabout</p>	10.07
FMR towards Cross Road.				

Day 2	Your Start Time	Time Allowed	Due Time @ TC		Total Distance	14.97 km
Section 5	: :	0:40:00	: :		SS Distance	2.03 km
TC 22	Belair Road				Time Allowed	0:40:00
TC 22A	Gouger Street Party				Average Speed	22.46 km/h
SS 22 - Windy Point						

Distance		Direction	Information	Distance To Go
Total	Part			

7.40	2.50	 12	SO @ XR 	7.57
------	------	--------	--------------------	------

9.45	2.05	 13	TL @ XR 	5.52
------	------	--------	--------------------	------

10.50	1.05	 14	TL @ XR (onto Greenhill Road)	4.47
-------	------	--------	--	------

Continue along Grenhill Road, crossing over Hutt Road, Unley Road, Peacock Road, and Sir Lewis Cohen Avenue.

12.92	2.42	 15	TR @ XR 	2.05
-------	------	--------	--------------------	------

Continue along Goodwood Road, following straight onto West Terrace. Cross over South Terrace, Sturt Street, Wright Street, and Gouger Street.

14.32	1.40	 16	TR @ XR 	0.65
-------	------	--------	--------------------	------

Day 2	Your Start Time	Time Allowed	Due Time @ TC		Total Distance	14.97 km
Section 5	: :	0:40:00	: :		SS Distance	2.03 km
TC 22	Belair Road				Time Allowed	0:40:00
TC 22A	Gouger Street Party				Average Speed	22.46 km/h
SS 22 - Windy Point						

Distance		Direction	Information	Distance To Go
Total	Part			
14.90	0.58		<p>TR @ XR</p> <p>Morphett St</p>	0.07
14.97	0.07		<p>TL (Hard to see) then TC IN</p> <p>Witcombe St</p>	0.00

Turn Left onto Gouger Street.
Follow the direction of Officials.

REMINDER:

No roadbook liaison section is provided to liaise from Gouger Street back to Parc Ferme. This is outlined in the Event's Supplementary Regulations.



ADELAIDE RALLY
• 2024 •

**2024 SHANNONS
ADELAIDE RALLY**
NOVEMBER 8-10



DAY 3

ADELAIDE RALLY

• 2024 •
Day 3 - Sunday
10th Nov. 2024

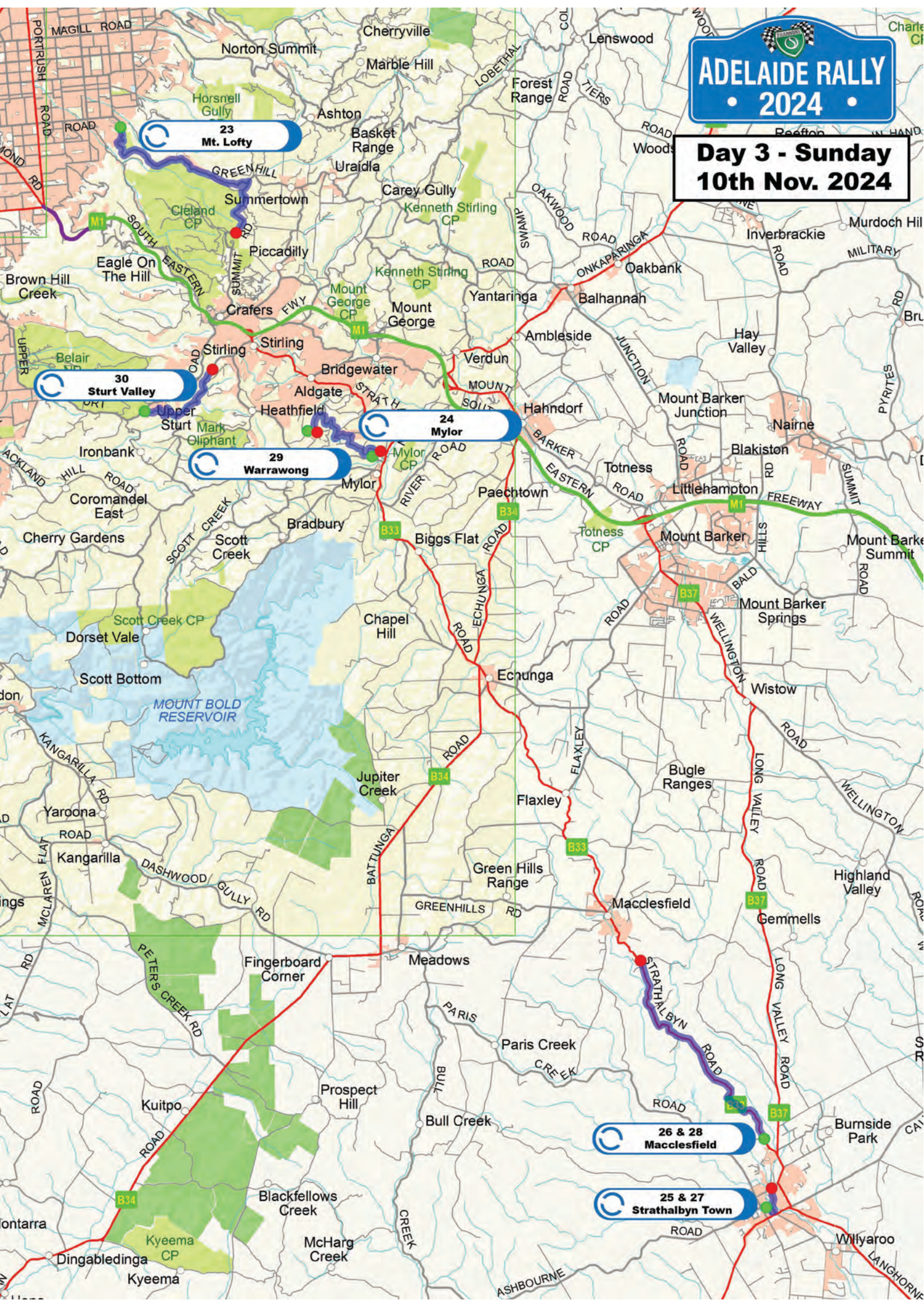

23 Mt. Lofty

30 Sturt Valley

29 Warrawong

24 Mylor

26 & 28 Macclesfield

25 & 27 Strathalbyn Town

2024 Shannons Adelaide Rally

Sunday, 10th November, 2024

Section:	TC/SS	Label	E	L	R	RV	Comp KM	Liaison KM	Section Total	Target Time	First Car
	1	22D	Depart Parc Ferme								
22E		Regroup I - Greenhill In	E					8.43	8.43	0:20	9:20
2	22F	Regroup I - Regroup Out						0.42	0.42	0:02	9:25
	23										
	SS 23	Mt. Lofty					7.56				9:27
	24						10.66	18.22	0:22		
3	SS 24	Mylor				RV	4.13				9:49
	24A	Regroup J - Strathalbyn Oval In	E				33.86	37.99	0:45		10:34
	24B	Regroup J - Strathalbyn Oval Out						0.34	0.34	0:02	10:39
4	25										
	SS 25	Strathalbyn Town Stage 1			R		0.53				10:41
	26						2.43	2.96	0:05		
	SS 26	Macclesfield 1			R		7.41				10:46
5	26A	Regroup K - Strathalbyn Town In	E	L			26.68	34.09	0:30		11:16
	26B	Regroup K - Strathalbyn Town Out						0.04	0.04	0:01	13:16
	27										
	SS 27	Strathalbyn Town Stage 2					0.53				13:17
	28						2.43	2.96	0:05		
5	SS 28	Macclesfield 2					7.41				13:22
	28A	Regroup L - Echunga In	E				12.15	19.56	0:25		13:47
	28B	Regroup L - Echunga Out						8.42	8.42	0:11	14:02
	29										
5	SS 29	Warrawong					3.82				14:13
	30						10.33	14.15	0:16		
	SS 30	Sturt Valley					3.20				14:29
	30A	Arrive Parc Ferme	E				20.33	23.53	0:30		14:59

DAILY TOTAL	34.59	136.52	171.11
--------------------	--------------	---------------	---------------

EVENT TOTAL	147.33	513.25	660.58
--------------------	---------------	---------------	---------------



'E' indicates entry to regroup or parc ferme without penalty.

'L' indicates designated lunch stop.

'R' indicates this stage is repeated on this day.

'RV' indicates this stage is reversed on this day.

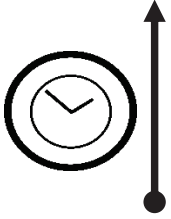
Day 3 Section 1	Your Start Time : : :	Time Allowed 0:20:00	Due Time @ TC : : :		Total Distance	8.43 km
TC 22D TC 22E	Adelaide Showgrounds Greenhill Road				Time Allowed	0:20:00
LIAISON ONLY					Average Speed	25.29 km/h
Distance		Direction	Information	Distance To Go		
Total	Part					
0.00	0.00	 1	 2	 3	0.00 Zero Trip Meter TC Out then 30m TL 	8.43
0.37	0.37		TL @ TJ	8.06		
1.10	0.73		TR @ XR 	7.33		
Continue along Greenhill Road. Cross over Glen Osmond Road, Fullarton Road and Portrush Road, until you reach the roundabout at Glynburn Road.						
7.61	6.51	 4	SO @ Roundabout	0.82		
8.43	0.82	 5	 then 130m TC In	0.00		

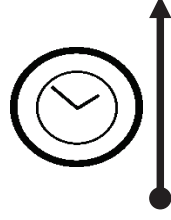
Day 3 Section 2	Your Start Time : : :	Time Allowed 0:02:00	Due Time @ TC : : :	Total Distance	0.42 km
TC 22F TC 23	Greenhill Road Greenhill Road			Time Allowed	0:02:00
LIAISON ONLY				Average Speed	12.60 km/h
Distance		Direction	Information	Distance To Go	
Total	Part				
0.00	0.00	 1	  TC Out	0.42	
0.42	0.42	 2	TC In then 30m Start	0.00	







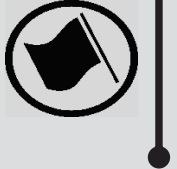

Day 3	Your Start Time	Time Allowed	Due Time @ TC		Total Distance	18.22 km
Section 2	: : :	0:22:00	: : :		SS Distance	7.56 km
TC 23	Greenhill Road				Time Allowed	0:22:00
TC 24	Forbes Road				Average Speed	49.69 km/h
SS 23 - Mt. Lofty						

Distance		Direction	Information	Distance To Go
Total	Part			

SS23

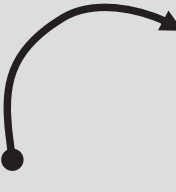
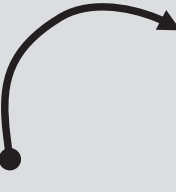





MOUNT LOFTY

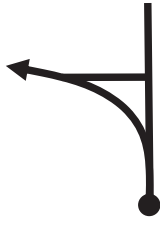
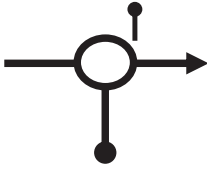

Day 3	Your Start Time	Time Allowed	Due Time @ TC			
Section 2	: : :	0:22:00	: : :		Total Distance	18.22 km
TC 23	Greenhill Road				SS Distance	7.56 km
TC 24	Forbes Road				Time Allowed	0:22:00
SS 23 - Mt. Lofty					Average Speed	49.69 km/h
Distance		Direction	Information	Distance To Go		
Total	Part					
0.00	0.00	 1 7.56	  Start S 34° 56.557 E 138° 40.320	18.22		
3.21	3.21	 2 4.35	RGR	15.01		
3.55	0.34	 3 4.01	RGR and Tightens	14.67		
3.78	0.23	 4 3.78	RGR and Tightens	14.44		
5.32	1.54	 5 2.24	RGL then RGR	12.90		
5.75	0.43	 6 1.81	TR 	12.47		

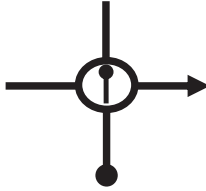
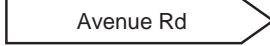
Day 3		Your Start Time	Time Allowed	Due Time @ TC		
Section 2		: :	0:22:00	: :	Total Distance	18.22 km
TC 23	Greenhill Road				SS Distance	7.56 km
TC 24	Forbes Road				Time Allowed	0:22:00
SS 23 - Mt. Lofty					Average Speed	49.69 km/h
Distance		Direction			Information	
Total	Part				Distance To Go	
6.00	0.25	<p>7 1.56</p>			Crest then RGR then RGL 12.22	
6.43	0.43	<p>8 1.13</p>			RGR 11.79	
6.61	0.18	<p>9 0.95</p>			RGR and Tightens then RGL and ! Care Tightens S 34° 57.851 E 138° 42.851 11.61	
6.98	0.37	<p>10 0.58</p>			 !! Caution RGL and Tightens S 34° 57.953 E 138° 42.688 11.24	
7.27	0.29	<p>11 0.29</p>			Start VC S 34° 58.066 E 138° 42.738 10.95	

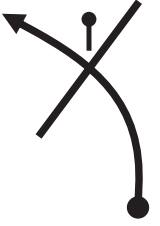
Day 3	Your Start Time	Time Allowed	Due Time @ TC			
Section 2	: : :	0:22:00	: : :		Total Distance	18.22 km
TC 23	Greenhill Road				SS Distance	7.56 km
TC 24	Forbes Road				Time Allowed	0:22:00
SS 23 - Mt. Lofty					Average Speed	49.69 km/h
Distance		Direction	Information	Distance To Go		
Total	Part					
7.47	0.20		<p>RGR End VC</p> <p>S 34° 58.152 E 138° 42.832</p>	10.75		
7.56	0.09		<p>Flying Finish on Crest</p> <p>S 34° 58.171 E 138° 42.814</p>	10.66		
7.75	0.19		<p>Stop Point</p> <p>S 34° 58.268 E 138° 42.736</p>	10.47		
8.80	1.05		<p>RGR FMR</p>	9.42		
11.49	2.69		<p>SO @ Roundabout</p>	6.73		
11.66	0.17		<p>SO @ Roundabout</p>	6.56		





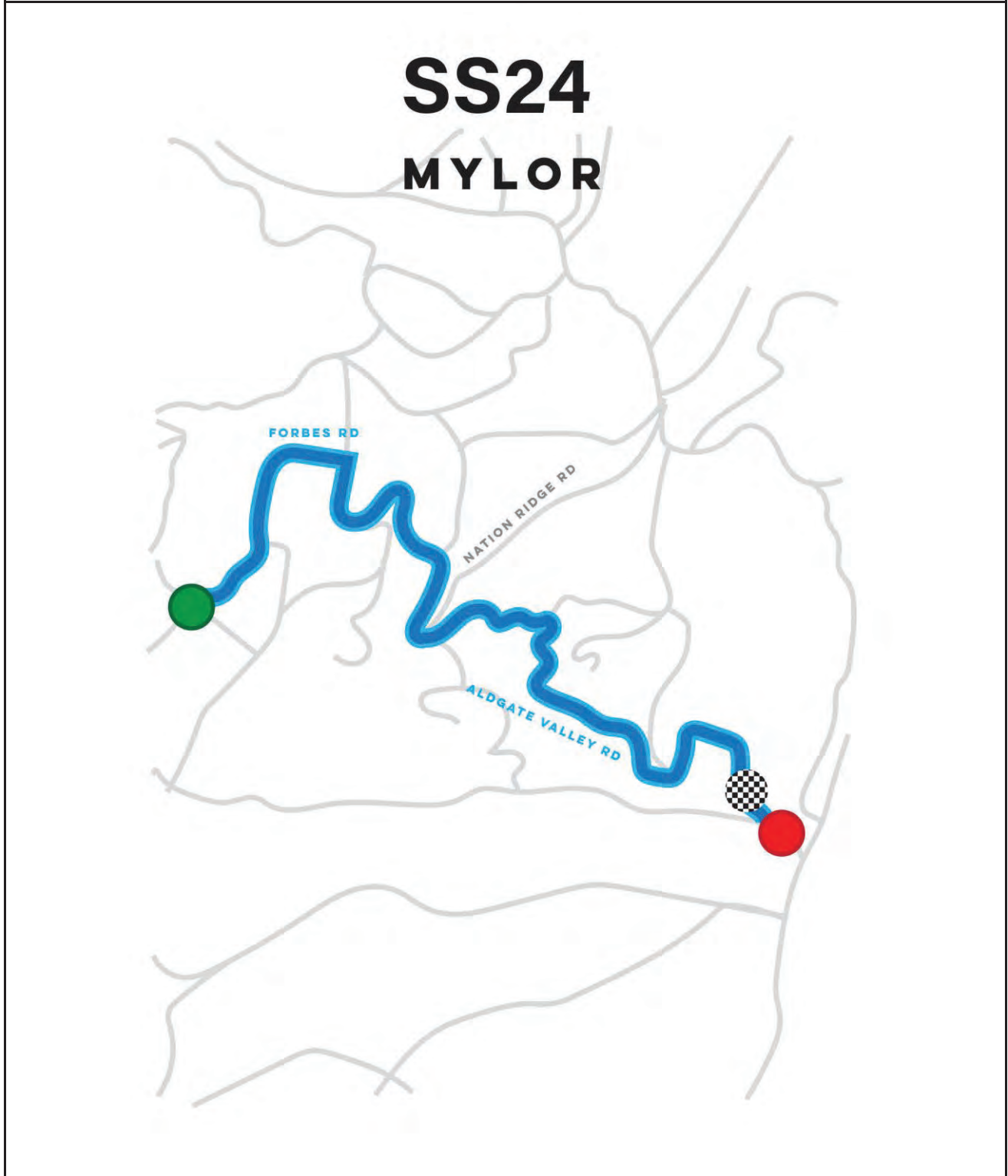

Day 3	Your Start Time	Time Allowed	Due Time @ TC		Total Distance	18.22 km
Section 2	: : :	0:22:00	: : :		SS Distance	7.56 km
TC 23	Greenhill Road				Time Allowed	0:22:00
TC 24	Forbes Road				Average Speed	49.69 km/h
SS 23 - Mt. Lofty						
Distance		Direction	Information	Distance To Go		
Total	Part					
11.90	0.24	 18	TL then 20m SO	6.32		
12.22	0.32	 19	TR @ Roundabout 	6.00		
12.57	0.35	 20	SO @ Roundabout	5.65		
13.04	0.47	 21	TR @ Roundabout 	5.18		
13.55	0.51	 22	KL	4.67		
15.66	2.11	 23	SO @ XR 	2.56		

Day 3	Your Start Time	Time Allowed	Due Time @ TC			
Section 2	: : :	0:22:00	: : :		Total Distance	18.22 km
TC 23	Greenhill Road				SS Distance	7.56 km
TC 24	Forbes Road				Time Allowed	0:22:00
SS 23 - Mt. Lofty					Average Speed	49.69 km/h
Distance		Direction	Information	Distance To Go		
Total	Part					
17.30	1.64	<p>24</p>	<p>TL</p>	0.92		
18.08	0.78	<p>25</p>	<p>SO @ XR</p>	0.14		
18.22	0.14	<p>26</p>	<p>TC In then 30m Start</p>	0.00		

Day 3	Your Start Time	Time Allowed	Due Time @ TC		Total Distance	38.07 km
Section 2	: :	0:45:00	: :		SS Distance	4.13 km
TC 24	Forbes Road				Time Allowed	0:45:00
TC 24A	Strathalbyn Oval				Average Speed	50.76 km/h
SS 24 - Mylor						

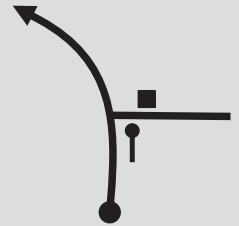
Distance		Direction	Information	Distance To Go
Total	Part			

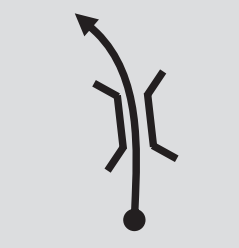

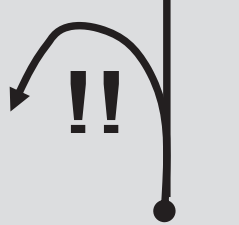
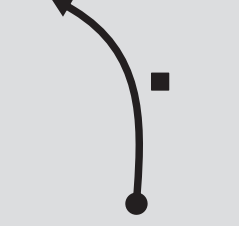







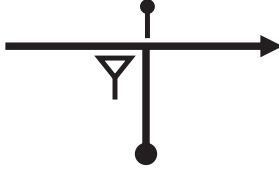
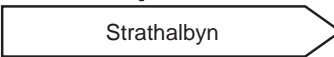

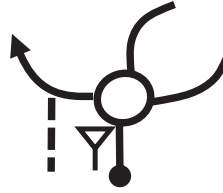
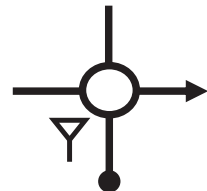
Day 3	Your Start Time	Time Allowed	Due Time @ TC			
Section 2	: : :	0:45:00	: : :		Total Distance	38.07 km
TC 24	Forbes Road				SS Distance	4.13 km
TC 24A	Strathalbyn Oval				Time Allowed	0:45:00
SS 24 - Mylor					Average Speed	50.76 km/h
Distance		Direction	Information	Distance To Go		
Total	Part					
0.00	0.00	 1 4.13	  Start then 50m RGR S 35° 01.848 E 138° 44.151	38.07		
0.22	0.22	 2 3.91	SO then RGL Keep in on Exit 	37.85		
0.75	0.53	 3 3.38	RGL on bridge THEN:	37.32		
0.84	0.09	 4 3.29	!! Caution TR @ TJ S 35° 01.565 E 138° 44.419	37.23		
1.10	0.26	 5 3.03	!! Caution KL then Tightens S 35° 01.703 E 138° 44.470	36.97		
1.50	0.40	 6 2.63	RGL Keep in on Exit	36.57		

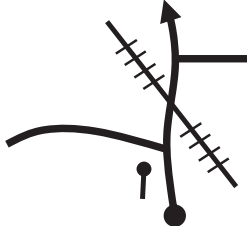
Day 3	Your Start Time	Time Allowed	Due Time @ TC			
Section 2	: : :	0:45:00	: : :		Total Distance	38.07 km
TC 24	Forbes Road				SS Distance	4.13 km
TC 24A	Strathalbyn Oval				Time Allowed	0:45:00
SS 24 - Mylor					Average Speed	50.76 km/h
Distance		Direction	Information	Distance To Go		
Total	Part					
1.70	0.20		<p>Start VC</p> <p>S 35° 01.797 E 138° 44.709</p>	36.37		
1.90	0.20		<p>End VC</p> <p>S 35° 01.898 E 138° 44.676</p>	36.17		
1.95	0.05		<p>!! Caution RGL then Tightens Keep in on Exit FMR</p> <p>S 35° 01.925 E 138° 44.654</p>	36.12		
2.60	0.65		<p>KR ! Care Possible Water on Road</p> <div style="border: 1px solid black; padding: 2px; display: inline-block;"> </div> <p>S 35° 01.916 E 138° 44.973</p>	35.47		
3.02	0.42		<p>Start VC</p> <p>S 35° 02.081 E 138° 45.015</p>	35.05		
3.22	0.20		<p>End VC Then RGL Keep in on Exit</p> <p>S 35° 02.134 E 138° 45.132</p>	34.85		

Day 3	Your Start Time	Time Allowed	Due Time @ TC			
Section 2	: : :	0:45:00	: : :		Total Distance	38.07 km
TC 24	Forbes Road				SS Distance	4.13 km
TC 24A	Strathalbyn Oval				Time Allowed	0:45:00
SS 24 - Mylor					Average Speed	50.76 km/h
Distance		Direction	Information	Distance To Go		
Total	Part			Go		
3.46	0.24	<p>13 0.67</p>	<p>! Care RGL Keep in on Exit</p> <p>S 35° 02.211 E 138° 45.232</p>	34.61		
3.79	0.33	<p>14 0.34</p>	<p>!! Caution Hump on Bridge then RGR</p> <p>S 35° 02.191 E 138° 45.351</p>	34.28		
4.13	0.34	<p>15 0.00</p>	<p>Flying Finish</p> <p>S 35° 02.234 E 138° 45.498</p>	33.94		
4.36	0.23	<p>16</p>	<p>Stop Point then TL @ TJ</p> <p>S 35° 02.345 E 138° 45.557</p>	33.71		
4.58	0.22	<p>17</p>	<p>GIVE WAY then TR @ TJ</p> <p>← Mylor Conservation Park</p>	33.49		
Continue into Echunga.						

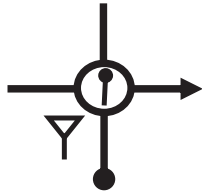
Day 3	Your Start Time	Time Allowed	Due Time @ TC			
Section 2	: : :	0:45:00	: : :		Total Distance	38.07 km
TC 24	Forbes Road				SS Distance	4.13 km
TC 24A	Strathalbyn Oval				Time Allowed	0:45:00
SS 24 - Mylor					Average Speed	50.76 km/h
Distance		Direction	Information	Distance To Go		
Total	Part					
12.21	7.63	 18	SO 	25.86		
12.41	0.20	 19	SO 	25.66		
12.93	0.52	 20	BR 	25.14		
13.09	0.16	 21	KL 	24.98		
FMR through Flaxley and into Macclesfield.						
22.48	9.39	 22	 TL @ XR 	15.59		

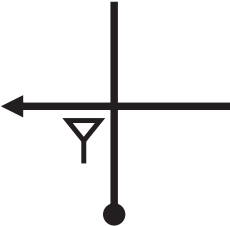
Day 3	Your Start Time	Time Allowed	Due Time @ TC			
Section 2	: : :	0:45:00	: : :		Total Distance	38.07 km
TC 24	Forbes Road				SS Distance	4.13 km
TC 24A	Strathalbyn Oval				Time Allowed	0:45:00
SS 24 - Mylor					Average Speed	50.76 km/h
Distance		Direction	Information	Distance To Go		
Total	Part					
28.66	6.18	 23	GIVE WAY then TR @ TJ NOTE: 100km Speed Zone 	9.41		
34.74	6.08	 24	SO 	3.33		
35.80	1.06	 25	GIVE WAY then TL @ Roundabout FMR	2.27		
36.66	0.86	 26	GIVE WAY then TR @ Roundabout (onto South Tce)	1.41		
37.01	0.35	 27	SO 	1.06		
37.18	0.17	 28	FMR over Train Line 	0.89		

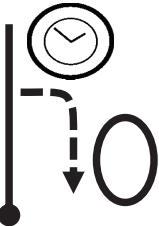





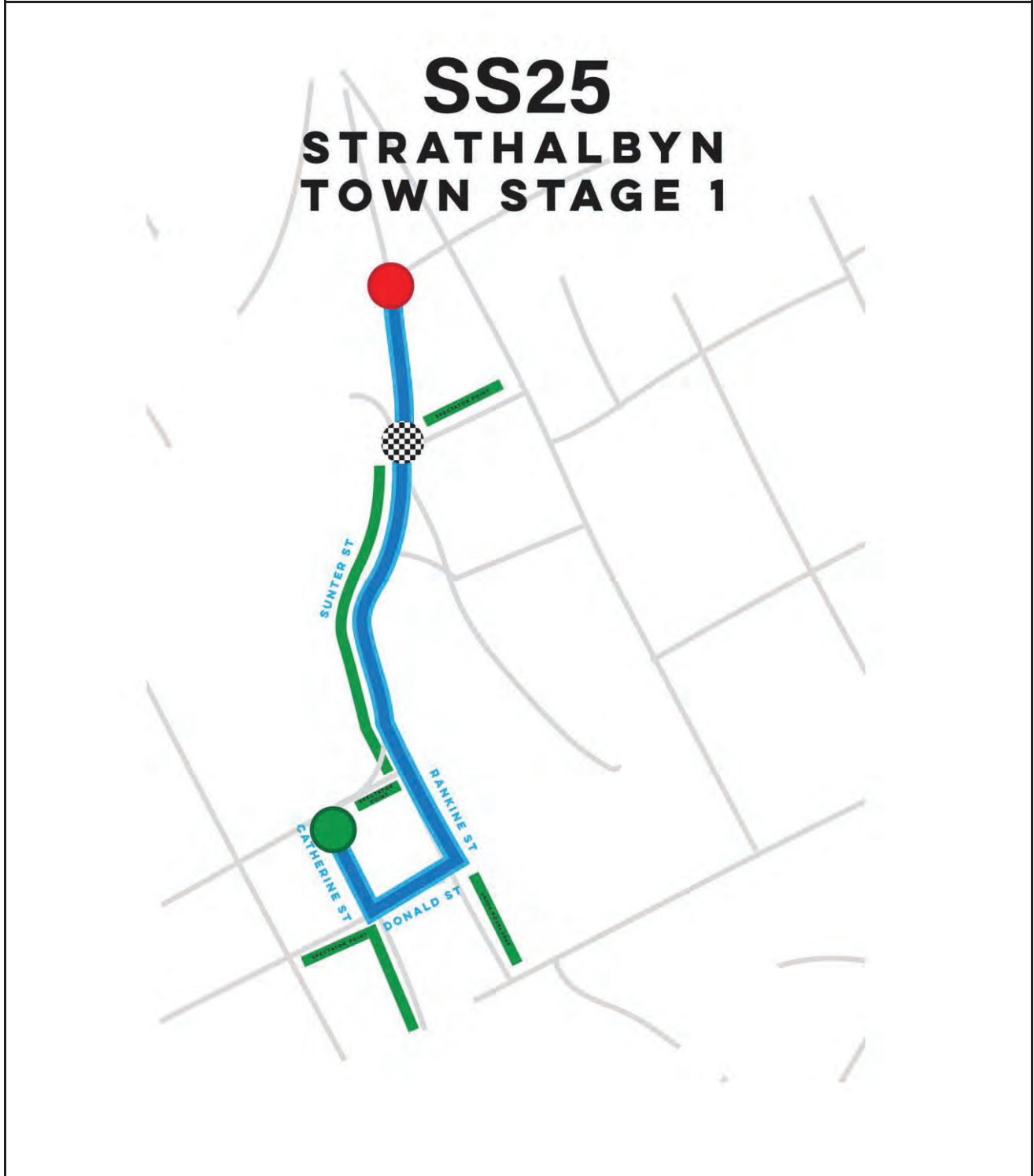

Day 3	Your Start Time	Time Allowed	Due Time @ TC		Total Distance	38.07 km
Section 2	: :	0:45:00	: :		SS Distance	4.13 km
TC 24	Forbes Road				Time Allowed	0:45:00
TC 24A	Strathalbyn Oval				Average Speed	50.76 km/h
SS 24 - Mylor						
Distance		Direction	Information	Distance To Go		
Total	Part					
37.55	0.37	 <p>29</p>	<p>GIVE WAY then TR @ Roundabout</p> 	0.52		
37.73	0.18	 <p>30</p>	<p>TL @ XR Oncoming Rally Traffic</p> 	0.34		
37.92	0.19	 <p>31</p>	<p>SO</p> <p>Rally Traffic Exiting on Right</p>	0.15		
38.07	0.15	 <p>32</p>	<p>TR into Oval TC In</p>	0.00		

Day 3	Your Start Time	Time Allowed	Due Time @ TC			
Section 3	: : :	0:02:00	: : :		Total Distance	0.34 km
TC 24B	Strathalbyn Oval					
TC 25	Cathrine Street				Time Allowed	0:02:00
LIAISON ONLY					Average Speed	10.20 km/h
Distance		Direction	Information	Distance To Go		
Total	Part					
0.00	0.00	<p>1</p>	<p>TC Out TL out of Oval Oncoming Rally Traffic</p>	0.34		
0.18	0.18	<p>2</p>	<p>GIVE WAY then SO @ XR</p>	0.16		
0.34	0.16	<p>3</p>	<p>TL @ TJ then 10m TR then 60m TR</p>	0.00		

Day 3	Your Start Time	Time Allowed	Due Time @ TC		Total Distance	2.96 km
Section 3	: : :	0:05:00	: : :		SS Distance	0.53 km
TC 25	Catherine Street				Time Allowed	0:05:00
TC 26	Strathalbyn Road				Average Speed	35.52 km/h
SS 25 - Strathalbyn Town Stage 1						

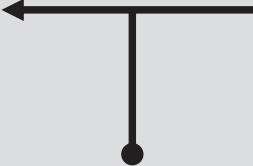
Distance		Direction	Information	Distance To Go
Total	Part			



Day 3		Your Start Time	Time Allowed	Due Time @ TC		
Section 3		: : :	0:05:00	: : :	Total Distance	2.96 km
TC 25	Catherine Street				SS Distance	0.53 km
TC 26	Strathalbyn Road				Time Allowed	0:05:00
SS 25 - Strathalbyn Town Stage 1					Average Speed	35.52 km/h
Distance		Direction			Information	
Total	Part				Distance To Go	
0.00	0.00	 1 0.53			   Start S 35° 15.551 E 138° 53.490	2.96
0.06	0.06	 2 0.47			TL @ XR	2.90
0.13	0.07	 3 0.40			TL @ TJ	2.83
0.17	0.04	 4 0.36			Slow Point S 35° 15.552 E 138° 53.544	2.79
0.25	0.08	 5 0.28			TR @ TJ around Water Barrier 	2.71
0.32	0.07	 6 0.21			SO over Bridge	2.64

Day 3	Your Start Time	Time Allowed	Due Time @ TC			
Section 3	: : :	0:05:00	: : :		Total Distance	2.96 km
TC 25	Catherine Street				SS Distance	0.53 km
TC 26	Strathalbyn Road				Time Allowed	0:05:00
SS 25 - Strathalbyn Town Stage 1					Average Speed	35.52 km/h
Distance		Direction	Information	Distance To Go		
Total	Part					
0.53	0.21	<p>7 0.00</p>	<p>KL of Barriers then 30m SO then 30m FF</p> <p>Swale St</p> <p>S 35° 15.351 E 138° 53.527</p>	2.43		
0.68	0.15	<p>8</p>	<p>Stop Point then SO</p> <p>Grey St</p> <p>S 35° 15.290 E 138° 53.512</p>	2.28		
0.84	0.16	<p>9</p>	<p>KR</p> <p>North Pde</p>	2.12		
1.13	0.29	<p>10</p>	<p>RGL then SO @ Roundabout</p>	1.83		
1.74	0.61	<p>11</p>	<p>RGL FMR</p> <p>Avenue/Rd</p>	1.22		
2.23	0.49	<p>12</p>	<p>GIVE WAY then TL</p> <p>Macclesfield</p>	0.73		

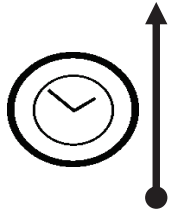
Day 3	Your Start Time	Time Allowed	Due Time @ TC			
Section 3	: : :	0:05:00	: : :		Total Distance	2.96 km
TC 25	Catherine Street				SS Distance	0.53 km
TC 26	Strathalbyn Road				Time Allowed	0:05:00
SS 25 - Strathalbyn Town Stage 1					Average Speed	35.52 km/h
Distance		Direction		Information		Distance To Go
Total	Part					
2.96	0.73			TC In then 30m Start		0.00
		13				





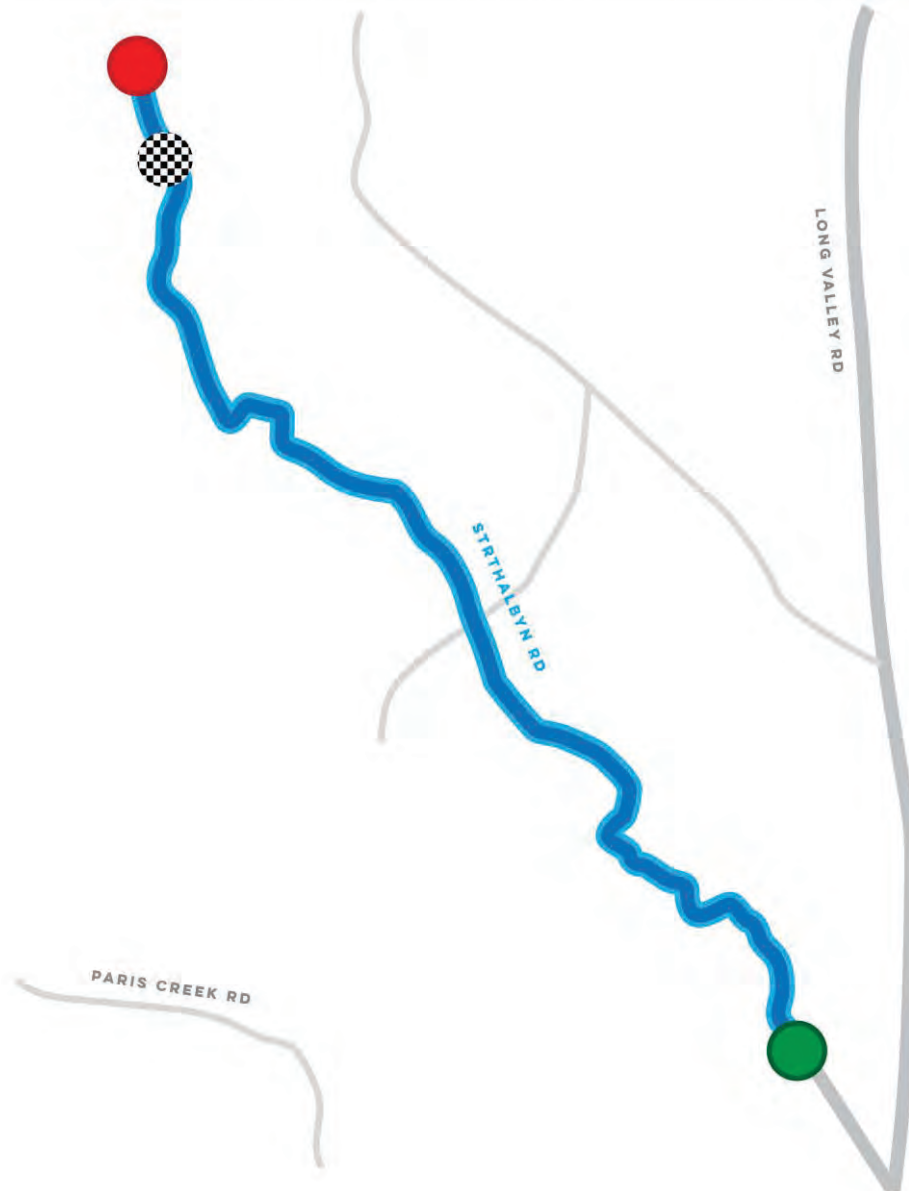

Day 3	Your Start Time	Time Allowed	Due Time @ TC		Total Distance	34.09 km
Section 3	: :	0:30:00	: :		SS Distance	7.41 km
TC 26	Strathalbyn Road				Time Allowed	0:30:00
TC 26A	Strathalbyn Town				Average Speed	68.18 km/h
SS 26 - Macclesfield 1						

Distance		Direction	Information	Distance To Go
Total	Part			

SS26

MACCLESFIELD 1

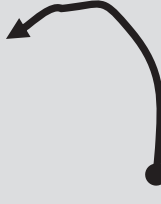

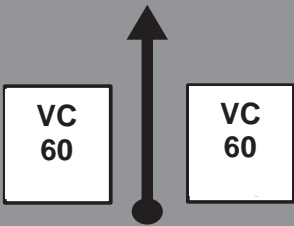





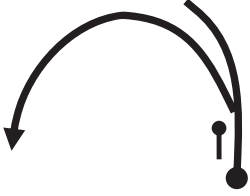

Day 3	Your Start Time	Time Allowed	Due Time @ TC		Total Distance	34.09 km
Section 3	: : :	0:30:00	: : :		SS Distance	7.41 km
TC 26	Strathalbyn Road				Time Allowed	0:30:00
TC 26A	Strathalbyn Town				Average Speed	68.18 km/h
SS 26 - Macclesfield 1						
Distance		Direction	Information	Distance To Go		
Total	Part					
0.00	0.00	 1 7.41	  Start S 35° 14.254 E 138° 53.339	34.09		
0.74	0.74	 2 6.67	RGL then RGR	33.35		
0.94	0.20	 3 6.47	RGL then Tightens	33.15		
1.60	0.66	 4 5.81	RGL then RGR then RGL	32.49		
2.15	0.55	 5 5.26	RGL	31.94		
2.45	0.30	 6 4.96	Start VC S 35° 13.336 E 138° 52.588	31.64		

Day 3	Your Start Time	Time Allowed	Due Time @ TC			
Section 3	: : :	0:30:00	: : :		Total Distance	34.09 km
TC 26	Strathalbyn Road				SS Distance	7.41 km
TC 26A	Strathalbyn Town				Time Allowed	0:30:00
SS 26 - Macclesfield 1					Average Speed	68.18 km/h
Distance		Direction	Information	Distance To Go		
Total	Part					
2.65	0.20		<p>End VC</p> <p>S 35° 13.295 E 138° 52.478</p>	31.44		
2.70	0.05		<p>RGL over Crest then 50m RGR</p>	31.39		
3.62	0.92		<p>Start VC</p> <p>S 35° 12.900 E 138° 52.098</p>	30.47		
3.82	0.20		<p>End VC</p> <p>S 35° 12.800 E 138° 52.062</p>	30.27		
4.36	0.54		<p>! Care RGL then Tightens</p> <p>S 35° 12.570 E 138° 51.868</p>	29.73		
4.59	0.23		<p>Start VC</p> <p>S 35° 12.524 E 138° 51.719</p>	29.50		

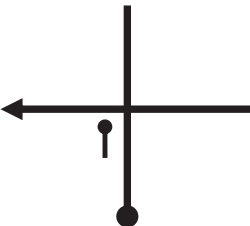
Day 3	Your Start Time	Time Allowed	Due Time @ TC			
Section 3	: : :	0:30:00	: : :		Total Distance	34.09 km
TC 26	Strathalbyn Road				SS Distance	7.41 km
TC 26A	Strathalbyn Town				Time Allowed	0:30:00
SS 26 - Macclesfield 1					Average Speed	68.18 km/h
Distance		Direction	Information	Distance To Go		
Total	Part					
4.79	0.20	<p>13 2.62</p>	<p>End VC as RGR Keep in on Exit S 35° 12.482 E 138° 51.595</p>	29.30		
5.03	0.24	<p>14 2.38</p>	<p>RGR and Tightens</p>	29.06		
5.58	0.55	<p>15 1.83</p>	<p>RGHR</p>	28.51		
6.08	0.50	<p>16 1.33</p>	<p>Start VC S 35° 12.102 E 138° 51.098</p>	28.01		

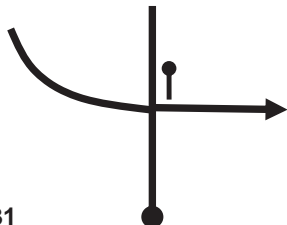
Day 3	Your Start Time	Time Allowed	Due Time @ TC		Total Distance	34.09 km
Section 3	: :	0:30:00	: :		SS Distance	7.41 km
TC 26	Strathalbyn Road				Time Allowed	0:30:00
TC 26A	Strathalbyn Town				Average Speed	68.18 km/h
SS 26 - Macclesfield 1						
Distance		Direction	Information	Distance To Go		
Total	Part					
6.28	0.20		<p>End VC then 30m RGL S 35° 12.005 E 138° 51.042</p>	27.81		
6.40	0.12		<p>! Care RGR S 35° 11.945 E 138° 50.975</p>	27.69		
6.54	0.14		<p>! Care RGR then RGL Small bump inside Keep in on Exit S 35° 11.871 E 138° 50.956</p>	27.55		
7.07	0.53		<p>RGL Keep in on Exit</p>	27.02		
7.41	0.34		<p>Flying Finish S 35° 11.443 E 138° 50.941</p>	26.68		
7.75	0.34		<p>Stop Point S 35° 11.274 E 138° 50.886</p>	26.34		
FMR to Macclesfield.						

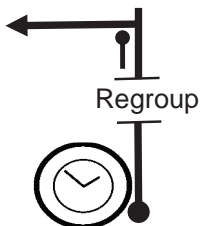
Day 3	Your Start Time	Time Allowed	Due Time @ TC		Total Distance	34.09 km
Section 3	: : :	0:30:00	: : :		SS Distance	7.41 km
TC 26	Strathalbyn Road				Time Allowed	0:30:00
TC 26A	Strathalbyn Town				Average Speed	68.18 km/h
SS 26 - Macclesfield 1						
Distance		Direction	Information	Distance To Go		
Total	Part					
10.06	2.31	 23	TL @ XR 	24.03		
11.86	1.80	 24	TL @ XR (Hard to See) 	22.23		
13.08	1.22	 25	KR 	21.01		
16.00	2.92	 26	SO 	18.09		
17.18	1.18	 27	SO 	16.91		
17.45	0.27	 28	! Care TVHL Hard to See 	16.64		

Day 3	Your Start Time	Time Allowed	Due Time @ TC		Total Distance	34.09 km
Section 3	: : :	0:30:00	: : :		SS Distance	7.41 km
TC 26	Strathalbyn Road				Time Allowed	0:30:00
TC 26A	Strathalbyn Town				Average Speed	68.18 km/h
SS 26 - Macclesfield 1						
Distance		Direction	Information	Distance To Go		
Total	Part					
19.27	1.82	 29	TL then RGL 	14.82		
33.92	14.65	 30	TL @ XR 	0.17		
34.08	0.16	 31	TR @ XR 	0.01		
34.09	0.01	 32	TC In then 500m RJTL 	0.00		

Day 3	Your Start Time	Time Allowed	Due Time @ TC		Total Distance	0.04 km
Section 4	: : :	0:01:00	: : :			
TC 26B	Strathalbyn Town					
TC 27	Cathrine Street				Time Allowed	0:01:00
LIAISON ONLY					Average Speed	2.40 km/h
Distance		Direction	Information	Distance To Go		
Total	Part					
0.00	0.00			<div style="border: 1px solid black; padding: 2px; display: inline-block;">0.00</div> <small>Zero Trip Meter</small> TC Out then TR <div style="border: 1px solid black; padding: 2px; display: inline-block; margin-top: 10px;">Cathrine St</div> TC In then 30m Start	0.04	
0.04	0.04			0.00		







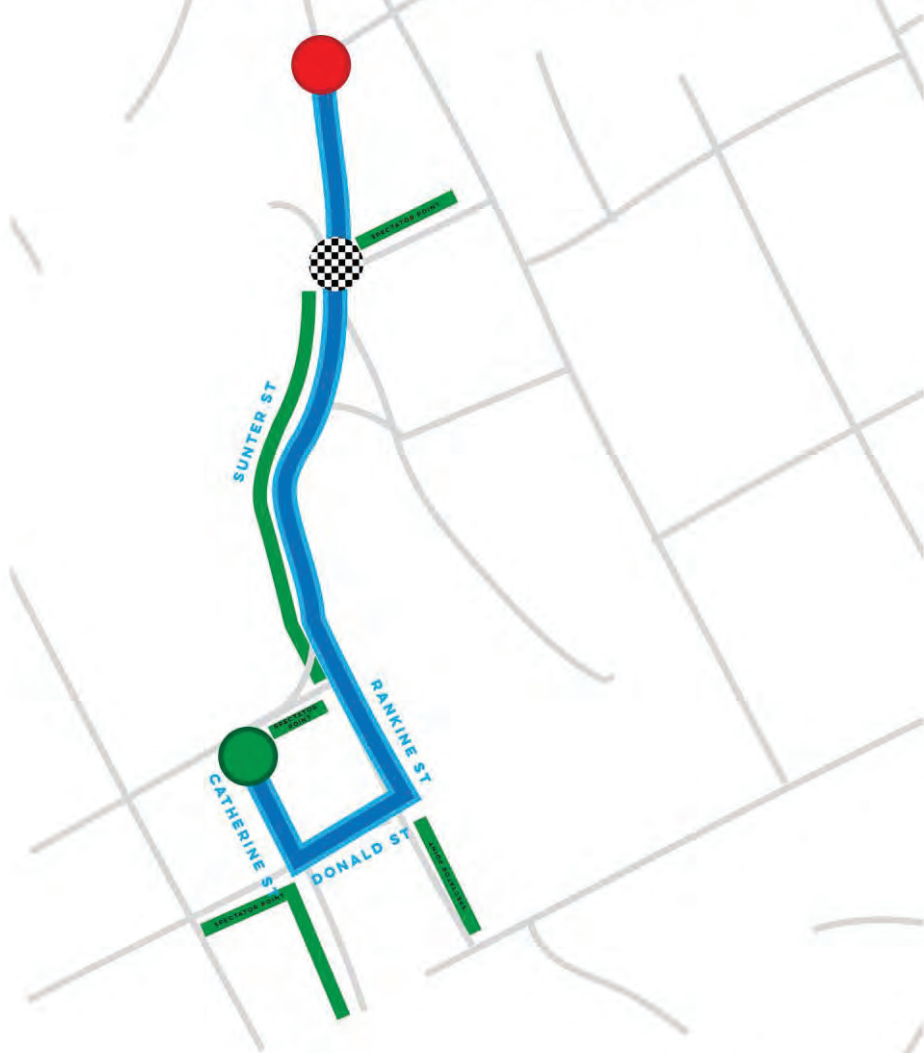

Day 3	Your Start Time	Time Allowed	Due Time @ TC		Total Distance	2.96 km
Section 4	: : :	0:05:00	: : :		SS Distance	0.53 km
TC 27	Catherine Street				Time Allowed	0:05:00
TC 28	Strathalbyn Road				Average Speed	35.52 km/h
SS 27 - Strathalbyn Town Stage 2						

Distance		Direction	Information	Distance To Go
Total	Part			

SS27

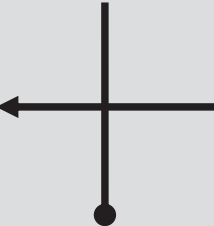
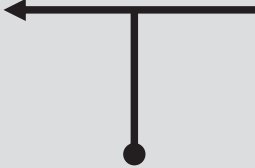
STRATHALBYN TOWN STAGE 2



Day 3	Your Start Time	Time Allowed	Due Time @ TC		Total Distance	2.96 km
Section 4	: : :	0:05:00	: : :		SS Distance	0.53 km
TC 27	Catherine Street				Time Allowed	0:05:00
TC 28	Strathalbyn Road				Average Speed	35.52 km/h
SS 27 - Strathalbyn Town Stage 2						
Distance		Direction	Information	Distance To Go		
Total	Part					
0.00	0.00	 1 0.53	   Start S 35° 15.551 E 138° 53.490	2.96		
0.06	0.06	 2 0.47	TL @ XR	2.90		
0.13	0.07	 3 0.40	TL @ TJ	2.83		
0.17	0.04	 4 0.36	Slow Point S 35° 15.552 E 138° 53.544	2.79		
0.25	0.08	 5 0.28	TR @ TJ around Water Barrier 	2.71		
0.32	0.07	 6 0.21	SO over Bridge	2.64		

Day 3	Your Start Time	Time Allowed	Due Time @ TC			
Section 4	: : :	0:05:00	: : :		Total Distance	2.96 km
TC 27	Catherine Street				SS Distance	0.53 km
TC 28	Strathalbyn Road				Time Allowed	0:05:00
SS 27 - Strathalbyn Town Stage 2					Average Speed	35.52 km/h
Distance		Direction	Information	Distance To Go		
Total	Part					
0.53	0.21	<p>7 0.00</p>	<p>KL of Barriers then 30m SO then 30m FF</p> <p>Swale St</p> <p>S 35° 15.351 E 138° 53.527</p>	2.43		
0.68	0.15	<p>8</p>	<p>Stop Point then SO</p> <p>Grey St</p> <p>S 35° 15.290 E 138° 53.512</p>	2.28		
0.84	0.16	<p>9</p>	<p>KR</p> <p>North Pde</p>	2.12		
1.13	0.29	<p>10</p>	<p>RGL then SO @ Roundabout</p>	1.83		
1.74	0.61	<p>11</p>	<p>RGL FMR</p> <p>Avenue/Rd</p>	1.22		
2.23	0.49	<p>12</p>	<p>GIVE WAY then TL</p> <p>Macclesfield</p>	0.73		

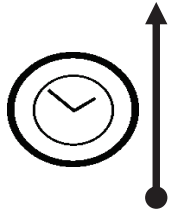
Day 3	Your Start Time	Time Allowed	Due Time @ TC			
Section 4	: : :	0:05:00	: : :		Total Distance	2.96 km
TC 27	Catherine Street				SS Distance	0.53 km
TC 28	Strathalbyn Road				Time Allowed	0:05:00
SS 27 - Strathalbyn Town Stage 2					Average Speed	35.52 km/h
Distance		Direction		Information		Distance To Go
Total	Part					
2.96	0.73			TC In then 30m Start		0.00
		13				





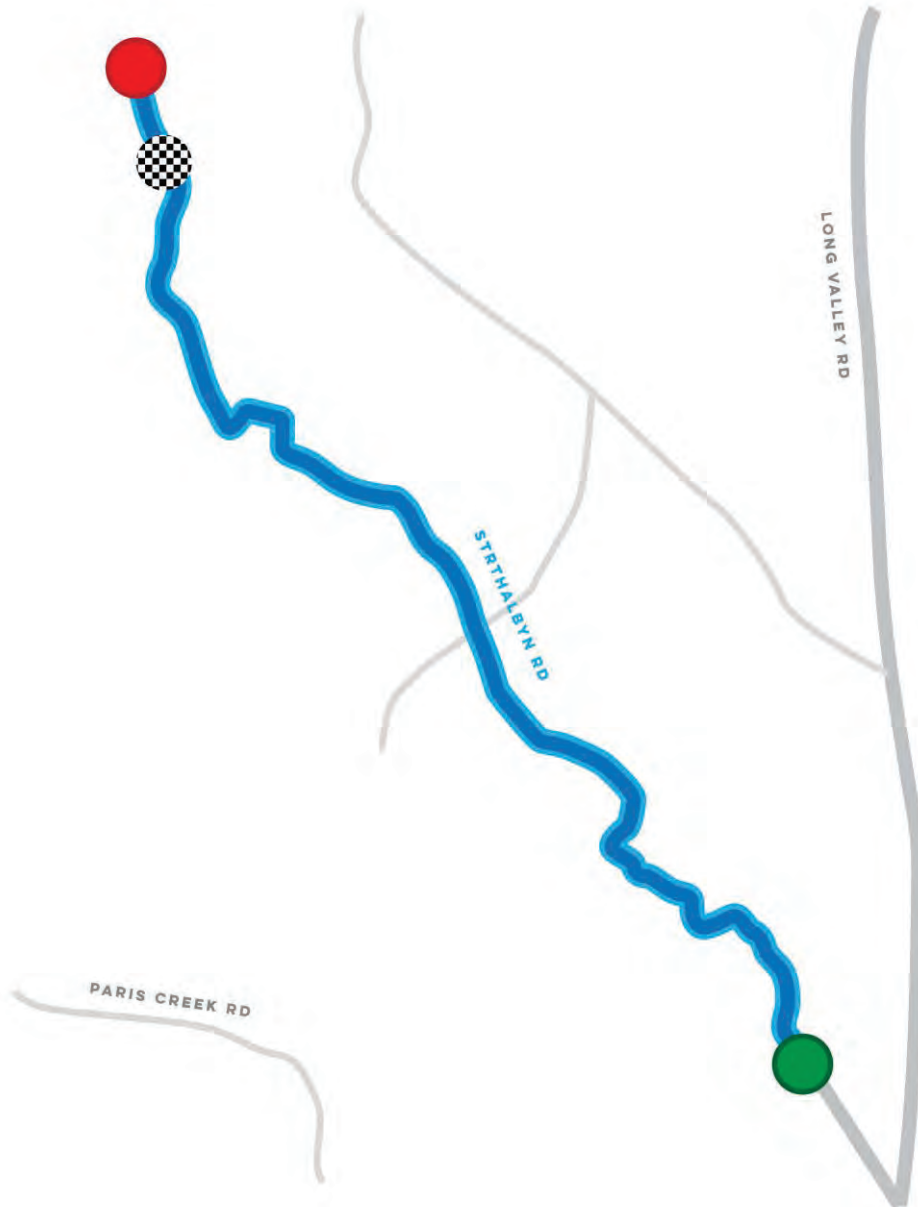

Day 3	Your Start Time	Time Allowed	Due Time @ TC		Total Distance	19.56 km
Section 4	: : :	0:25:00	: : :		SS Distance	7.41 km
TC 28	Strathalbyn Road				Time Allowed	0:25:00
TC 28A	Echunga Main Street				Average Speed	46.94 km/h
SS 28 - Macclesfield 2						

Distance		Direction	Information	Distance To Go
Total	Part			

SS28

MACCLESFIELD 2



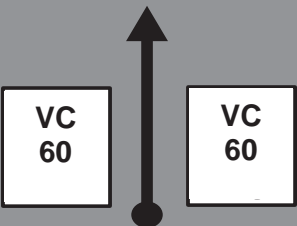



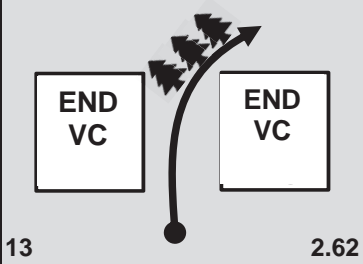
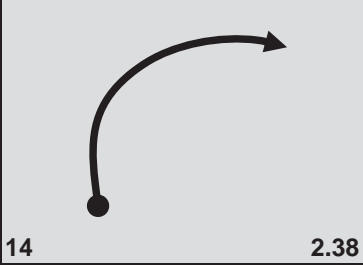
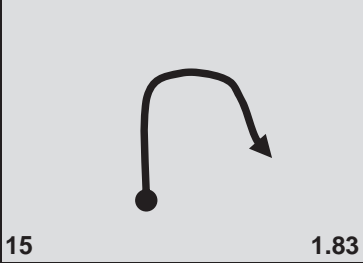
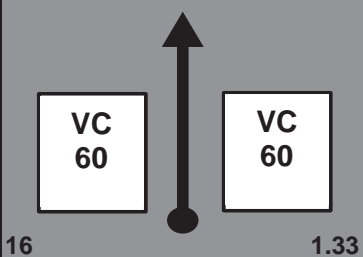



Day 3	Your Start Time	Time Allowed	Due Time @ TC			
Section 4	: : :	0:25:00	: : :		Total Distance	19.56 km
TC 28	Strathalbyn Road				SS Distance	7.41 km
TC 28A	Echunga Main Street				Time Allowed	0:25:00
SS 28 - Macclesfield 2					Average Speed	46.94 km/h
Distance		Direction	Information	Distance To Go		
Total	Part					
0.00	0.00	 1 7.41	  Start S 35° 14.254 E 138° 53.339	19.56		
0.74	0.74	 2 6.67	RGL then RGR	18.82		
0.94	0.20	 3 6.47	RGL then Tightens	18.62		
1.60	0.66	 4 5.81	RGL then RGR then RGL	17.96		
2.15	0.55	 5 5.26	RGL	17.41		
2.45	0.30	 6 4.96	Start VC S 35° 13.336 E 138° 52.588	17.11		

Day 3	Your Start Time	Time Allowed	Due Time @ TC		Total Distance	19.56 km
Section 4	: : :	0:25:00	: : :		SS Distance	7.41 km
TC 28	Strathalbyn Road				Time Allowed	0:25:00
TC 28A	Echunga Main Street				Average Speed	46.94 km/h
SS 28 - Macclesfield 2						
Distance		Direction	Information	Distance To Go		
Total	Part					
2.65	0.20		<p>End VC</p> <p>S 35° 13.295 E 138° 52.478</p>	16.91		
2.70	0.05		<p>RGL over Crest then 50m RGR</p>	16.86		
3.62	0.92		<p>Start VC</p> <p>S 35° 12.900 E 138° 52.098</p>	15.94		
3.82	0.20		<p>End VC</p> <p>S 35° 12.800 E 138° 52.062</p>	15.74		
4.36	0.54		<p>! Care RGL then Tightens</p> <p>S 35° 12.570 E 138° 51.868</p>	15.20		
4.59	0.23		<p>Start VC</p> <p>S 35° 12.524 E 138° 51.719</p>	14.97		

Day 3	Your Start Time	Time Allowed	Due Time @ TC		Total Distance	19.56 km
Section 4	: :	0:25:00	: :		SS Distance	7.41 km
TC 28	Strathalbyn Road				Time Allowed	0:25:00
TC 28A	Echunga Main Street				Average Speed	46.94 km/h
SS 28 - Macclesfield 2						
Distance		Direction	Information	Distance To Go		
Total	Part					
4.79	0.20		End VC as RGR Keep in on Exit S 35° 12.482 E 138° 51.595	14.77		
5.03	0.24		RGR and Tightens	14.53		
5.58	0.55		RGHR	13.98		
6.08	0.50		Start VC S 35° 12.102 E 138° 51.098	13.48		

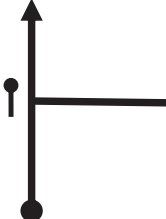
Day 3	Your Start Time	Time Allowed	Due Time @ TC			
Section 4	: :	0:25:00	: :		Total Distance	19.56 km
TC 28	Strathalbyn Road				SS Distance	7.41 km
TC 28A	Echunga Main Street				Time Allowed	0:25:00
SS 28 - Macclesfield 2					Average Speed	46.94 km/h
Distance		Direction	Information	Distance To Go		
Total	Part					
6.28	0.20		<p>End VC then 30m RGL S 35° 12.005 E 138° 51.042</p>	13.28		
6.40	0.12		<p>! Care RGR S 35° 11.945 E 138° 50.975</p>	13.16		
6.54	0.14		<p>! Care RGR then RGL Small bump inside Keep in on Exit S 35° 11.871 E 138° 50.956</p>	13.02		
7.07	0.53		<p>RGL Keep in on Exit</p>	12.49		
7.41	0.34		<p>Flying Finish S 35° 11.443 E 138° 50.941</p>	12.15		
7.75	0.34		<p>Stop Point S 35° 11.274 E 138° 50.886</p>	11.81		
FMR through Macclesfield & Flaxley to Echunga.						

Day 3	Your Start Time	Time Allowed	Due Time @ TC			
Section 4	: :	0:25:00	: :		Total Distance	19.56 km
TC 28	Strathalbyn Road				SS Distance	7.41 km
TC 28A	Echunga Main Street				Time Allowed	0:25:00
SS 28 - Macclesfield 2					Average Speed	46.94 km/h
Distance		Direction	Information	Distance To Go		
Total	Part					
19.45	11.70		BR	0.11		
19.56	0.11		TC In then FMR	0.00		

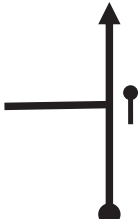
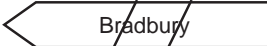
Day 3	Your Start Time	Time Allowed	Due Time @ TC		Total Distance	8.42 km
Section 5	: : :	0:11:00	: : :			
TC 28B	Echunga Main Street				Time Allowed	0:11:00
TC 29	Aldgate Valley Road				Average Speed	45.93 km/h
LIAISON ONLY						
Distance		Direction	Information	Distance To Go		
Total	Part					
0.00	0.00	 1	 0.00 Zero Trip Meter TC Out then SO 	8.42		
0.12	0.12	 2	FMR 	8.30		
0.31	0.19	 3	SO 	8.11		
1.20	0.89	 4	KR over Crest 	7.22		
7.70	6.50	 5	SO 	0.72		

Day 3	Your Start Time	Time Allowed	Due Time @ TC		Total Distance	8.42 km
Section 5	: : :	0:11:00	: : :			
TC 28B	Echunga Main Street				Time Allowed	0:11:00
TC 29	Aldgate Valley Road				Average Speed	45.93 km/h
LIAISON ONLY						
Distance						Distance To Go
Total	Part	Direction		Information		
8.00	0.30	 6		TL Stock Rd		0.42
8.15	0.15	 7		TR Aldgate Valley Rd		0.27
8.42	0.27	 8		TC In then 30m Start		0.00







Day 3	Your Start Time	Time Allowed	Due Time @ TC			
Section 5	: : :	0:16:00	: : :		Total Distance	14.15 km
TC 29	Aldgate Valley Road				SS Distance	3.82 km
TC 30	Sturt Valley Road				Time Allowed	0:16:00
SS 29 - Warrawong					Average Speed	53.06 km/h



Distance		Direction	Information	Distance To Go
Total	Part			



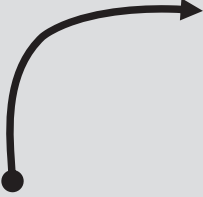

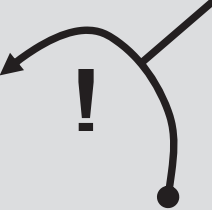

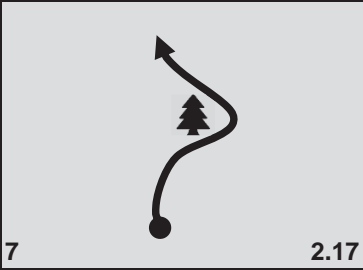
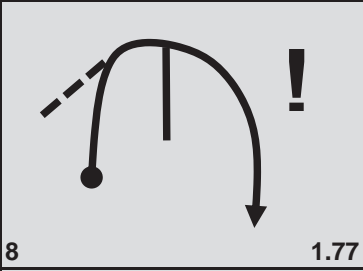
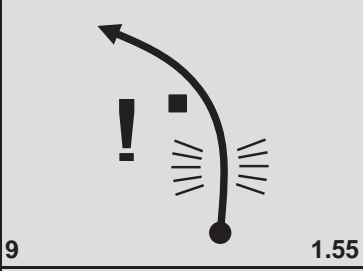
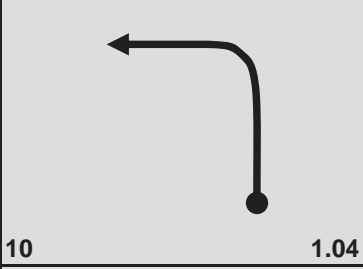
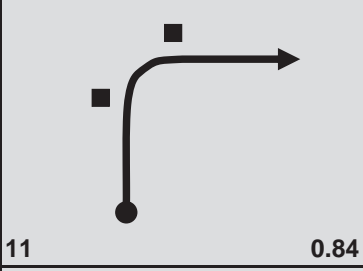
SS29



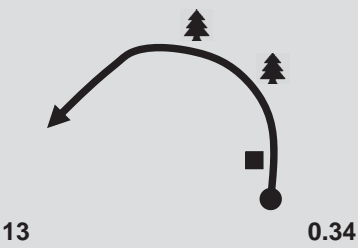
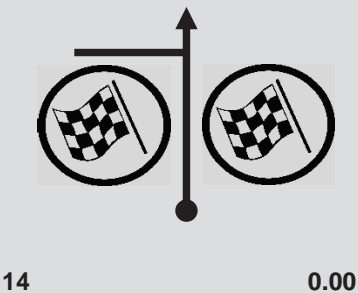

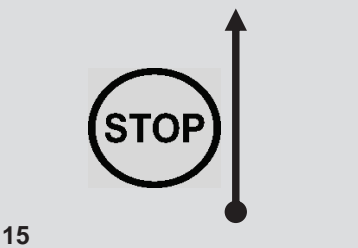
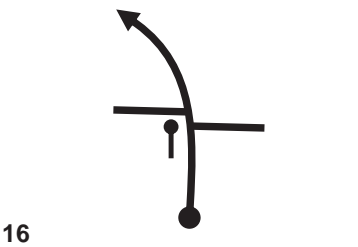
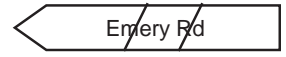
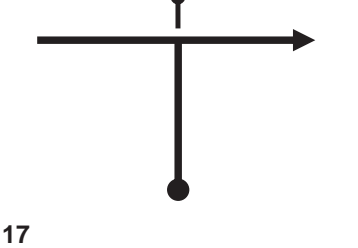

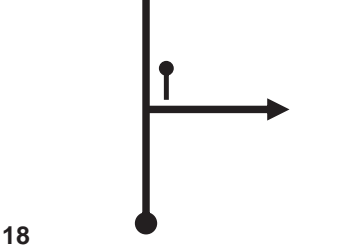
WARRAWONG

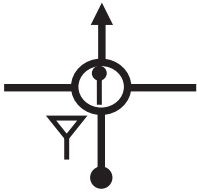
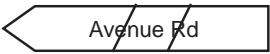
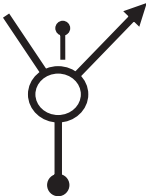

Day 3	Your Start Time	Time Allowed	Due Time @ TC			
Section 5	: :	0:16:00	: :		Total Distance	14.15 km
TC 29	Aldgate Valley Road				SS Distance	3.82 km
TC 30	Sturt Valley Road				Time Allowed	0:16:00
SS 29 - Warrarwong					Average Speed	53.06 km/h
Distance		Direction	Information	Distance To Go		
Total	Part					
0.00	0.00	 1 3.82	  Start S 35° 02.223 E 138° 45.498	14.15		
0.21	0.21	 2 3.61	! Care RGL and Tightens over Bridge S 35° 02.151 E 138° 45.394	13.94		
0.44	0.23	 3 3.38	RGR	13.71		
0.54	0.10	 4 3.28	RGR	13.61		
1.14	0.60	 5 2.68	! Care RGR then RGL S 35° 02.071 E 138° 44.979	13.01		
1.32	0.18	 6 2.50	RGR then RGL ! Care Possible Water on Road S 35° 01.936 E 138° 44.983	12.83		

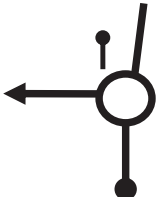
Day 3	Your Start Time	Time Allowed	Due Time @ TC			
Section 5	: : :	0:16:00	: : :		Total Distance	14.15 km
TC 29	Aldgate Valley Road				SS Distance	3.82 km
TC 30	Sturt Valley Road				Time Allowed	0:16:00
SS 29 - Warrarong					Average Speed	53.06 km/h
Distance		Direction	Information	Distance To Go		
Total	Part					
1.65	0.33		RGR Keep in on Exit then RGL	12.50		
2.05	0.40		! Care RGHR FMR S 35° 01.953 E 138° 44.688	12.10		
2.27	0.22		! Care Crest then RGL Keep in on Exit S 35° 01.823 E 138° 44.705	11.88		
2.78	0.51		RGL	11.37		
2.98	0.20		RGR then Tightens Keep in on Exit	11.17		
3.25	0.27		!! Caution TL Downhill Don't Cut Keep in on Exit S 35° 01.584 E 138° 44.455	10.90		

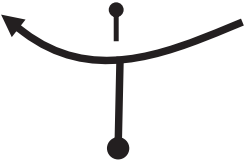
Day 3	Your Start Time	Time Allowed	Due Time @ TC		Total Distance	14.15 km
Section 5	: : :	0:16:00	: : :		SS Distance	3.82 km
TC 29	Aldgate Valley Road				Time Allowed	0:16:00
TC 30	Sturt Valley Road				Average Speed	53.06 km/h
SS 29 - Warrarwong						
Distance		Direction	Information	Distance To Go		
Total	Part					
3.48	0.23		RGL then 40m Tightens Keep in on Exit	10.67		
3.82	0.34		Flying Finish then 60m SO @ RJ  S 35° 01.712 E 138° 44.233	10.33		
4.10	0.28		Stop Point S 35° 01.843 E 138° 44.157	10.05		
4.25	0.15		SO @ XR 	9.90		
5.03	0.78		TR @ TJ 	9.12		
5.84	0.81		TR Hard to See 	8.31		

Day 3	Your Start Time	Time Allowed	Due Time @ TC			
Section 5	: : :	0:16:00	: : :		Total Distance	14.15 km
TC 29	Aldgate Valley Road				SS Distance	3.82 km
TC 30	Sturt Valley Road				Time Allowed	0:16:00
SS 29 - Warrarong					Average Speed	53.06 km/h
Distance		Direction	Information	Distance To Go		
Total	Part					
9.15	3.31	 19	GIVE WAY then SO @ Roundabout Potential Rally Traffic on left 	5.00		
9.65	0.50	 20	TR @ Roundabout 	4.50		
10.02	0.37	 21	TL @ Roundabout 	4.13		
10.30	0.28	 22	TL @ TJ 	3.85		

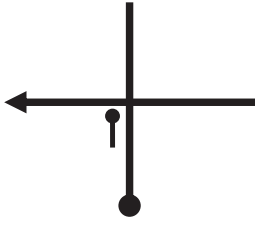
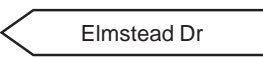
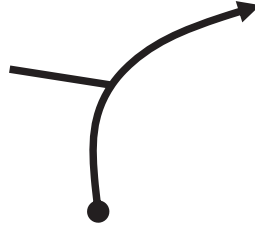
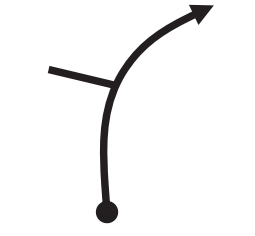
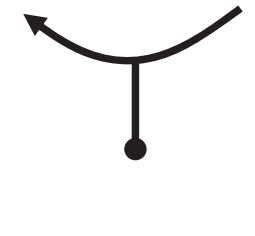
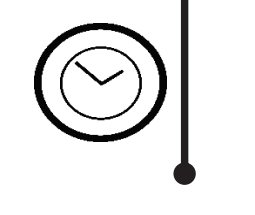
Day 3		Your Start Time	Time Allowed	Due Time @ TC			
Section 5		: :	0:16:00	: :	Total Distance	14.15 km	
TC 29	Aldgate Valley Road				SS Distance	3.82 km	
TC 30	Sturt Valley Road				Time Allowed	0:16:00	
SS 29 - Warrarwong					Average Speed	53.06 km/h	
Distance		Direction			Information		
Total	Part				Distance To Go		
13.65	3.35				TL @ XR 		0.50
13.73	0.08				FMR		0.42
13.90	0.17				KR		0.25
14.13	0.23				TL @ TJ		0.02
14.15	0.02				TC In then 30m Start		0.00









Day 3	Your Start Time	Time Allowed	Due Time @ TC		Total Distance	23.53 km
Section 5	: : :	0:30:00	: : :		SS Distance	3.20 km
TC 30	Sturt Valley Road				Time Allowed	0:30:00
TC 30A	Event Finale				Average Speed	47.06 km/h
SS 30 - Sturt Valley						





Distance		Direction	Information	Distance To Go
Total	Part			

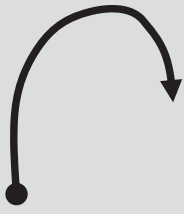

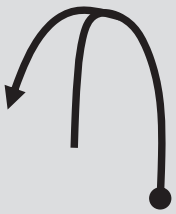

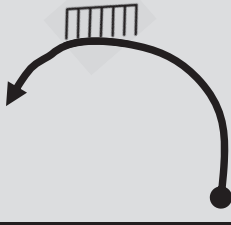

SS30

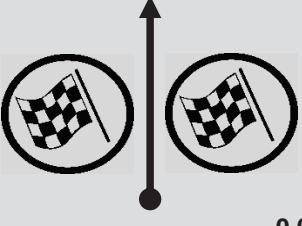

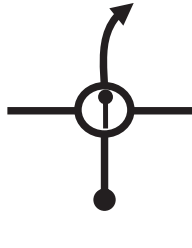

STURT VALLEY

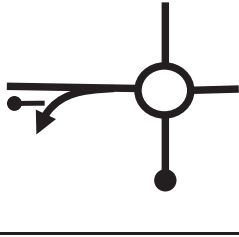

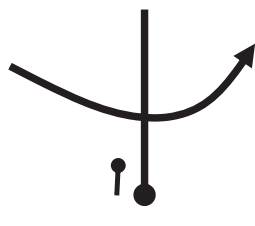
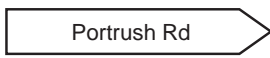
Day 3	Your Start Time	Time Allowed	Due Time @ TC			
Section 5	: : :	0:30:00	: : :		Total Distance	23.53 km
TC 30	Sturt Valley Road				SS Distance	3.20 km
TC 30A	Event Finale				Time Allowed	0:30:00
SS 30 - Sturt Valley					Average Speed	47.06 km/h
Distance		Direction	Information	Distance To Go		
Total	Part					
0.00	0.00	 1 3.20	   Start S 35° 01.430 E 138° 40.775	23.53		
0.05	0.05	 2 3.15	RGL over Crest	23.48		
0.27	0.22	 3 2.93	! Care RGL S 35° 01.419 E 138° 40.941	23.26		
0.39	0.12	 4 2.81	RGR	23.14		
0.56	0.17	 5 2.64	RGL then RGR	22.97		
0.70	0.14	 6 2.50	RGL FMR	22.83		

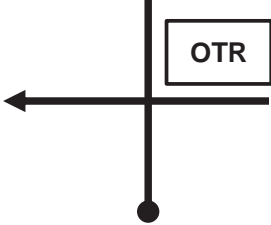
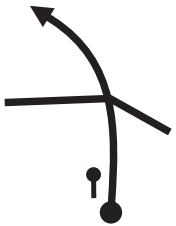
Day 3	Your Start Time	Time Allowed	Due Time @ TC			
Section 5	: : :	0:30:00	: : :		Total Distance	23.53 km
TC 30	Sturt Valley Road				SS Distance	3.20 km
TC 30A	Event Finale				Time Allowed	0:30:00
SS 30 - Sturt Valley					Average Speed	47.06 km/h
Distance		Direction	Information	Distance To Go		
Total	Part					
0.98	0.28	 7 2.22	! Care RGL then 30m Hairpin Right S 35° 01.382 E 138° 41.155	22.55		
1.27	0.29	 8 1.93	! Care SO then 50m Narrow Bridge S 35° 01.476	22.26		
1.45	0.18	 9 1.75	TL @ TJ	22.08		
2.26	0.81	 10 0.94	RGL then Tightens and Narrows	21.27		
2.68	0.42	 11 0.52	RGL then RGR	20.85		
3.20	0.52	 12 0.00	Flying Finish S 35° 00.880 E 138° 41.966	20.33		

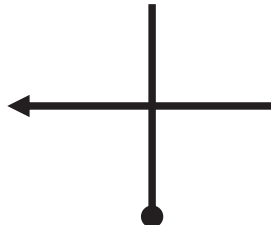
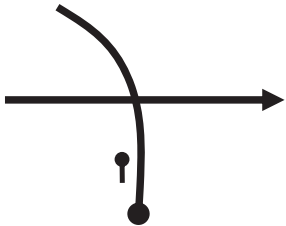
Day 3	Your Start Time	Time Allowed	Due Time @ TC			
Section 5	: : :	0:30:00	: : :		Total Distance	23.53 km
TC 30	Sturt Valley Road				SS Distance	3.20 km
TC 30A	Event Finale				Time Allowed	0:30:00
SS 30 - Sturt Valley					Average Speed	47.06 km/h
Distance		Direction	Information	Distance To Go		
Total	Part					
3.42	0.22	 13	Stop Point S 35° 00.766 E 138° 42.053	20.11		
4.47	1.05	 14	TL @ TJ ! Care Potential Rally Traffic on Right	19.06		
4.95	0.48	 15	SO @ Roundabout ! Care Potential Rally Traffic Exiting on Left. Do Not Follow. 	18.58		
5.26	0.31	 16	TL @ Roundabout then 50m KL 	18.27		
Continue on the South Eastern Freeway towards Adelaide CBD.						
15.04	9.78	 17	Move to Right Lane TR @ XR 	8.49		
Continue on Portrush Road, crossing over Greenhill Road, Kensington Road, & The Parade. Move to the left lane, and prepare to turn left onto Magill Road.						

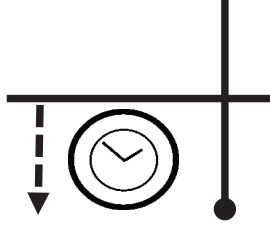
Day 3	Your Start Time	Time Allowed	Due Time @ TC			
Section 5	: : :	0:30:00	: : :		Total Distance	23.53 km
TC 30	Sturt Valley Road				SS Distance	3.20 km
TC 30A	Event Finale				Time Allowed	0:30:00
SS 30 - Sturt Valley					Average Speed	47.06 km/h
Distance		Direction	Information	Distance To Go		
Total	Part					
20.45	5.41	 18	TL @ XR (onto Magill Rd)	3.08		
22.03	1.58	 19	RJSO (onto North Tce) 	1.50		
22.85	0.82	 20	XRTL (onto Dequetteville Terrace)	0.68		
23.10	0.25	 21	XRTR (onto Rundle Road) 	0.43		
23.53	0.43	 22	TL @ XR (onto East Terrace) then 100m TL TC In	0.00		
Enter Rymill Park and follow the directions of Officials.						



ADELAIDE RALLY
• 2024 •

**2024 SHANNONS
ADELAIDE RALLY**
NOVEMBER 8-10



ROAD BOOK FORMS



QUERY FORM

This form is used to formally request information or clarification from the Event.

Please hand this form to a senior Rally Official as soon as possible

CAR NUMBER:	
Name:	Contact Number:
Details of Query:	Time/Date:
Signature:	
OFFICE USE ONLY	
What action has been taken?	
What action is required?	

Use other side of page for more information if required.

This page intentionally left blank.



QUERY FORM

This form is used to formally request information or clarification from the Event.

Please hand this form to a senior Rally Official as soon as possible

CAR NUMBER:	
Name:	Contact Number:
Details of Query:	Time/Date:
Signature:	
OFFICE USE ONLY	
What action has been taken?	
What action is required?	

Use other side of page for more information if required.

This page intentionally left blank.



INCIDENT REPORT FORM

This form is to be completed and forwarded to the Clerk of the Course / Event Office

Originator		
<input type="checkbox"/> MIV CREW	<input type="checkbox"/> CONTRACTOR	<input type="checkbox"/> COMPETITOR
<input type="checkbox"/> SEC	<input type="checkbox"/> OFFICIALS e.g. Officials, Volunteers	
DETAILS OF PEOPLE INVOLVED		
Reporting Name:	Telephone Number:	Vehicle Number/s
Date of Incident:	Time of Incident:	Location:
REPORT DETAILS		
Nature of incident/hazard		
<input type="checkbox"/> Theft	<input type="checkbox"/> Personal Injury*	<input type="checkbox"/> Property Damage
<input type="checkbox"/> Medical Condition	<input type="checkbox"/> House Keeping/Maintenance	<input type="checkbox"/> Safety Hazard/Near Miss/Spill*
<input type="checkbox"/> Unauthorised entry	<input type="checkbox"/> Bomb Threat/Violence/Security Risk*	
*Report immediately to the Clerk of Course / Event Office.		
What Occurred?		
What is the consequence?		
What action has been taken?		
What action is required (if any)?		
Name of any witness:		
Contact details of witness:		
Reported By:	Role:	
Contact Number:	Signature:	
Name of Senior Official:		
USE OVERSIDE FOR FURTHER DETAILS AND/OR SKETCHES; WITNESS DETAILS		

This page intentionally left blank.



INCIDENT REPORT FORM

This form is to be completed and forwarded to the Clerk of the Course / Event Office

Originator		
<input type="checkbox"/> MIV CREW	<input type="checkbox"/> CONTRACTOR	<input type="checkbox"/> COMPETITOR
<input type="checkbox"/> SEC	<input type="checkbox"/> OFFICIALS e.g. Officials, Volunteers	
DETAILS OF PEOPLE INVOLVED		
Reporting Name:	Telephone Number:	Vehicle Number/s
Date of Incident:	Time of Incident:	Location:
REPORT DETAILS		
Nature of incident/hazard		
<input type="checkbox"/> Theft	<input type="checkbox"/> Personal Injury*	<input type="checkbox"/> Property Damage
<input type="checkbox"/> Medical Condition	<input type="checkbox"/> House Keeping/Maintenance	<input type="checkbox"/> Safety Hazard/Near Miss/Spill*
<input type="checkbox"/> Unauthorised entry	<input type="checkbox"/> Bomb Threat/Violence/Security Risk*	
*Report immediately to the Clerk of Course / Event Office.		
What Occurred?		
What is the consequence?		
What action has been taken?		
What action is required (if any)?		
Name of any witness:		
Contact details of witness:		
Reported By:	Role:	
Contact Number:	Signature:	
Name of Senior Official:		
USE OVERSIDE FOR FURTHER DETAILS AND/OR SKETCHES; WITNESS DETAILS		

This page intentionally left blank.



COMPETITION RESTART FORM

Competitor: Please complete this form and obtain the required signatures before handing it to a Regroup or Service Out control to be able to rejoin the event.

Service / Regroup Out Control: If the form has been correctly signed off, please allow this competitor to rejoin the event as close as possible (but after) the road position detailed below.

CAR NUMBER:	<input type="text"/>
Location of Temp Withdrawal (Stage name & No):	
<input type="text"/>	
Reason for Temp Withdrawal:	
<input type="text"/>	
Any Property Damage or Injury?	
<input type="text"/>	
Lodged By:	Signature:
Contact Number:	Time/Date:
(Official Use Only)	
Restart Approvals:	
Competitor Relations Officer	<input type="text"/> Initials
Chief Scrutineer or Delegate	<input type="text"/> Initials
Expected Restart Position (after car #)	<input type="text"/>
Clerk of Course or Delegate	<input type="text"/> Initials
Restart Control:	<input type="text"/> Initials
Actual Restart Position (after car #)	<input type="text"/> Control Official Initials <input type="text"/>

This page intentionally left blank.



COMPETITION RESTART FORM

Competitor: Please complete this form and obtain the required signatures before handing it to a Regroup or Service Out control to be able to rejoin the event.

Service / Regroup Out Control: If the form has been correctly signed off, please allow this competitor to rejoin the event as close as possible (but after) the road position detailed below.

CAR NUMBER:	<input type="text"/>
Location of Temp Withdrawal (Stage name & No):	
<input type="text"/>	
Reason for Temp Withdrawal:	
<input type="text"/>	
Any Property Damage or Injury?	
<input type="text"/>	
Lodged By:	Signature:
Contact Number:	Time/Date:
(Official Use Only)	
Restart Approvals:	
Competitor Relations Officer	<input type="text"/> Initials
Chief Scrutineer or Delegate	<input type="text"/> Initials
Expected Restart Position (after car #)	<input type="text"/>
Clerk of Course or Delegate	<input type="text"/> Initials
Restart Control:	<input type="text"/> Initials
Actual Restart Position (after car #)	<input type="text"/> Control Official Initials <input type="text"/>

This page intentionally left blank.



WITHDRAWAL FROM COMPETITION FORM

Please hand to a Rally Official as soon as possible

CAR NUMBER:	
Location: 	
Reason for Withdrawal: 	
Any Property Damage or Injury? 	
What is happening to the Crew and Vehicle? 	
Lodged by:	Signature:
Contact Number:	Time/Date:

This page intentionally left blank.



WITHDRAWAL FROM COMPETITION FORM

Please hand to a Rally Official as soon as possible

CAR NUMBER:	
Location: 	
Reason for Withdrawal: 	
Any Property Damage or Injury? 	
What is happening to the Crew and Vehicle? 	
Lodged by:	Signature:
Contact Number:	Time/Date:

This page intentionally left blank.